



# Sports Facilities Planning Guide

 **Abu Dhabi**  
Sports Council  
مجلس أبوظبي الرياضي

**Technical Standards - 1st Version 2023**  
Properties and Investment Department - Properties  
Section 2023  
FO-S01-06-07



## Vision

Abu Dhabi is a global capital of sports. Practice .. Competition .. Hosting ..

## Mission

Create a sports environment that contributes to raising awareness of the importance of sports, providing programs and events for practicing it among members of society, applying the best international systems that qualify for professional sports competition at the local and international levels, and hosting the most important international tournaments.

## Executive Summary

This Sports Facilities Planning Guide provides guidelines for the general principles for planning sports facilities, the required sizes and the type of materials used to implement the site for the practice of each activity in terms of standards and specifications of international and local federations for each sport. The Guide also provides a method for calculating the capacity of all facilities according to (the law) known as the applicable building code in the Emirate of Abu Dhabi and the stages of sports facilities planning.

This Guide aims to ensure that the design and implementation of sports facilities are followed in accordance with legal specifications and standards, taking into account security, health and safety standards





## Guide Contents

General principles for sports facilities planning .....	08
Capacity for each facility .....	18
Population density .....	26
Sports Facilities Planning Phases .....	30
Designing a site for practicing sports activity .....	34
Common mistakes in sports facilities .....	98

# 1

## **General principles for sports facilities planning**



## Site selection

The selection of the site depends on many factors, the foremost of which is the type of sports facility to be established (small playgrounds, training centers, sports stadium...etc), the available space for that facility, its distance from residential areas, and ease of transportation, as well as other factors must be taken into account, such as : Future population growth and their needs, as well as the availability of basic services (water, electricity, sanitation, transportation network, distance from sources of pollution and disturbance, etc.)

## Basic principles for planning sports facilities:

Closed playgrounds	Open/outdoor playgrounds
<b>Wind directions</b>	
<p>With regard to air movement, it is preferable that the direction of the building allow air to permeate inside and around the building, and to take advantage of the northwest wind, the building can be tilted slightly to the north.</p>	<p>The wind has an effect on the movement performance of athletes in outdoor playgrounds, and therefore the wind factor must be taken into account when choosing the location of the facility. Putting the playgrounds in the direction of the wind according to its axis so that the two teams face the wind with the same strength and proportion throughout the two halves of the match.</p>
<b>The degree of the sun inclination on the playgrounds</b>	
<p>The optimal direction of the building is that its longitudinal axis to be east-west, so the southern façade receives the largest amount of heat in winter and the least amount of heat in the northern façade in summer. Therefore, the optimal direction of the openings for hot areas is northeastern.</p>	<p>The direction of inclination of the sun's rays affects the performance of the players, referees and spectators as well. Therefore, the playing field must be directly exposed to the sun's rays without there being any barriers (natural or artificial) that block parts of the rays from the playground, so there must be equality in the distribution of rays for all users.</p> <p>Therefore, the following must be taken into account:1. Place the playground in a way that allows the distribution of sun rays in the periods of sunrise and sunset in an equal proportion between the two halves of the playground and equal in terms of vision for the two teams (for competitors).2. It is preferable that the longitudinal axis of the playing field be directed from north to south to ensure an even distribution of rays, and this can be adjusted according to the location by no more than (15 degrees).</p>
<b>The degree of the playground floors inclination</b>	
<p>The need to place a slight inclination / incline in the floors of all playgrounds in order to facilitate the flow of excess water as a result of cleanliness and maintenance in the indoor playgrounds- It should not exceed 0.15%, and the degree of inclination should always be in a perpendicular direction to the direction of the playground</p>	<p>The need to place a slight inclination / incline in the floors of all playgrounds in order to facilitate the flow of rainwater in the outdoor playgrounds.- It should not exceed 0.5%, and the degree of inclination should always be in a perpendicular direction to the direction of the playground</p>

## Optimal direction: Open playgrounds

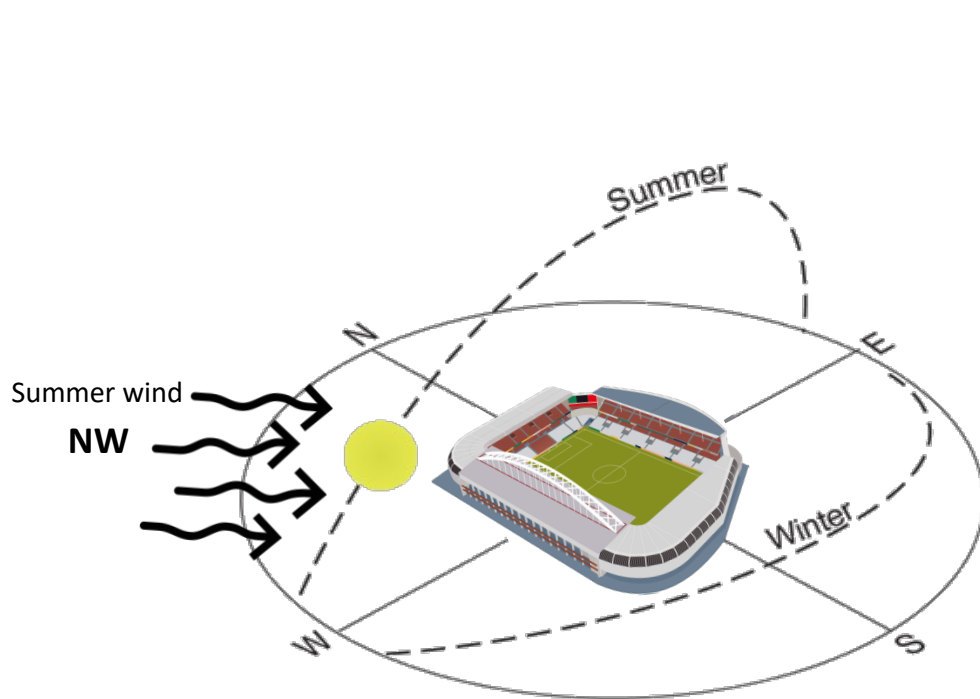

- It is preferable that the longitudinal axis of the playing field be directed from north to south to ensure a fair distribution of rays at sunrise and sunset periods in an equal proportion between the two halves of the playground and equal in terms of vision for the two teams.
- Optimal direction of the open playgrounds is one of the important principles in the planning phase
- It is generally recommended that the playgrounds be directed in a north-south direction to minimize the impact of sunset on players
- The best common direction is 15 degrees east of north

## Optimal direction: Closed playgrounds (facilities).

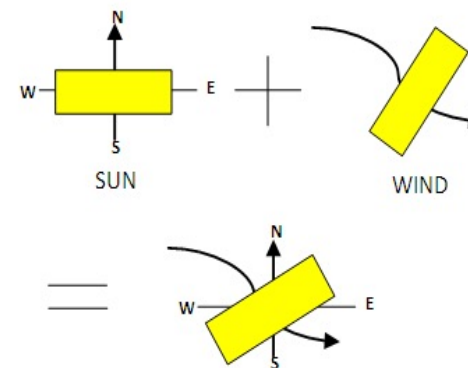
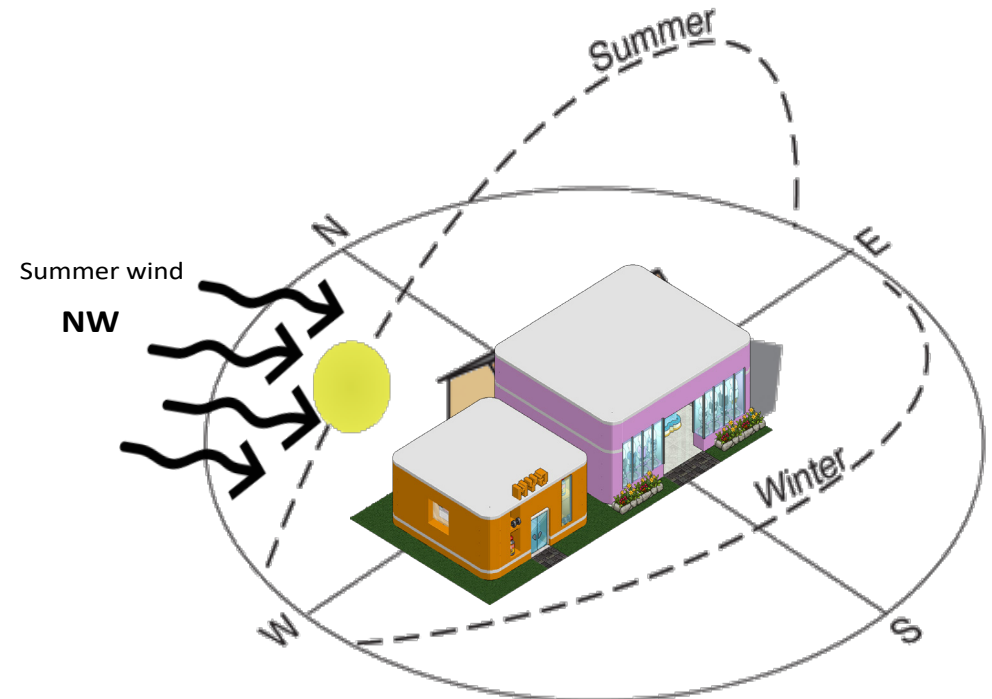

- The optimal direction of the building is that its longitudinal axis to be east-west, so the southern façade receives the largest amount of heat in winter and the least amount of heat in the northern façade in summer. Therefore, the optimal direction of the openings for hot areas is northeastern.



## Economic aspects

The financial costs of construction shall not be an obstacle to the establishment's realization of its vital value, and the following shall be followed:

- The possibility of dividing the project into multiple phases
- Develop a development plan according to the budgets allocated to the project (in the long and short term)
- Reduce financial costs as much as possible without compromising the quality of construction and operation
- Achieve goals at the lowest costs (economy in operation and electricity without affecting performance)
- Exploit the site's spaces and the multiplicity of facilities and their uses

To achieve the above economic goals, it is preferable to have an operator of the facility in the initial (preliminary) design stages

## Supervision

There are many aspects related to supervision, the most important of which are:

- The places of supervision should facilitate the process of communication with all places of activity in the facility
- It is preferable that the places and supervision rooms overlook the fields of the facility with good viewing angles (their facades are made of glass).
- Places for supervision must be provided in all units of the sports facility
- Places of supervision must be appropriate to control its management

## Security, safety and public health

Factors related to the security, safety and health of athletes must be taken into account, for example:

- The facility should be far from places of pollution, danger and disturbance (factories, airports...etc.)
- The presence of sufficient spaces free of any hard or sharp materials around the playground floors
- The number of doors leading to the playgrounds and their capacity is commensurate with the number of beneficiaries, and that the doors open to the outside in order to avoid overcrowding.
- That all maintenance tools and sports equipment be completely away from the playgrounds floors
- Allocation a first aid room
- Allocation of places for alarms and fire extinguishers according to the rules of civil defense
- Security surveillance cameras
- The number of toilets and their sizes are commensurate with the number of visitors to the sports facility
- Taking care of drinking water sources, sanitation, daily hygiene and periodic maintenance
- Pay attention to good ventilation and adequate lighting
- Continuous care in leveling and cleaning playgrounds' floors, and making sure that they are free of any harm to players
- Isolate the crowd areas from the playgrounds floors with barriers that do not obstruct or distort the playgrounds
- Consider allocating places for press and media personnel
- Observe the emergency exits

## Possibility of expansion in the future

The process of expanding or modifying some aspects of sports facilities in the future is likely to happen, especially in the era of modern technologies, and for this the following must be taken into account:

- Taking into account the continuous development processes in the technology of sports equipment
- Considering the possibility of amending the laws for sports playgrounds
- Taking into account the possibility of increasing the number of users of the sports facility
- Taking into account the possibility of expanding the facility horizontally or vertically
- Taking into account to leave enough space to build temporary stands for spectators around the playgrounds in large projects with large land areas and not containing fixed stands for spectators in which tournaments can be hosted

## Optimal utilization

Operating the sports facility to its maximum extent, and making the most of it as much as possible, is the golden rule. The increase of operating hours for more than one purpose is evidence of the facility's positivity, and this is done by organizing its operating program for different periods throughout the day to suit different beneficiaries with an attempt to continue use in all seasons of the year regardless of weather factors, i.e. the weather factor is not an obstacle to the continuity of use.

Therefore, the following must be taken into account:

- Utilizing the space, location and capabilities of the facility for more than one purpose
- Establishing more than one sports field to make maximum use of the spaces
- Using the finest materials that can withstand constant pressure
- Organizing multiple programs in all seasons and events



# 2

## **Capacity for each facility**

## Abu Dhabi International Building Code:

### How to calculate the capacity of each facility: -

- Calculate the area (m<sup>2</sup>) for each space
- Determine the classification and type of use for each space
- Choose the occupied capacity factor for the space from Abu Dhabi International Building Code (ADIBC) according to the classification of use for each space

To obtain the number of users for each space through the following equation:

- Space area (square meters) / occupied capacity factor for space (square meters per person)

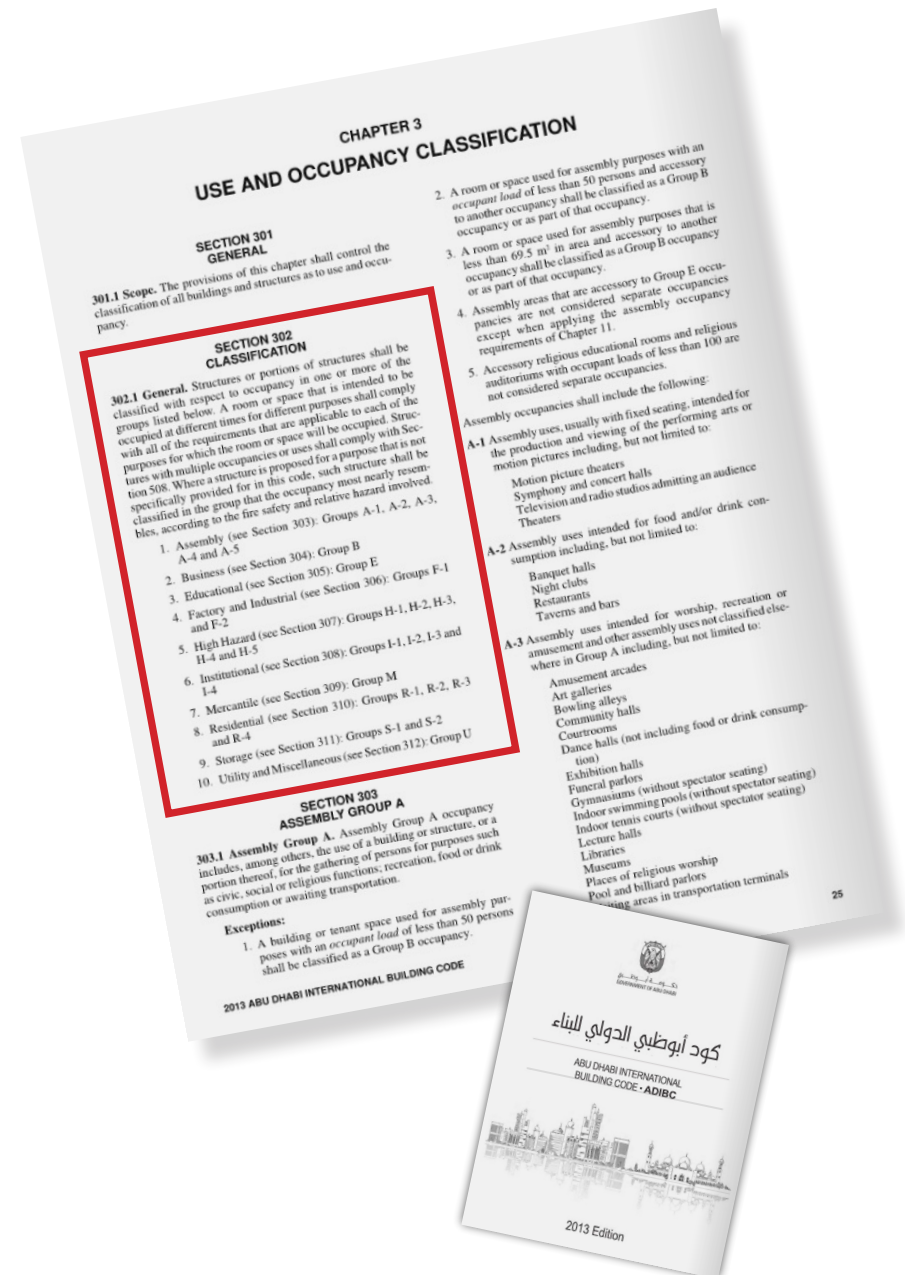



# Abu Dhabi International Building Code:

## CHAPTER 3

### USE AND OCCUPANCY CLASSIFICATION

#### SECTION 301 GENERAL

**301.1 Scope.** The provisions of this chapter shall control the classification of all buildings and structures as to use and occupancy.

#### SECTION 302 CLASSIFICATION

**302.1 General.** Structures or portions of structures shall be classified with respect to occupancy in one or more of the groups listed below. A room or space that is intended to be occupied at different times for different purposes shall comply with all of the requirements that are applicable to each of the purposes for which the room or space will be occupied. Structures with multiple occupancies or uses shall comply with Section 508. Where a structure is proposed for a purpose that is not specifically provided for in this code, such structure shall be classified in the group that the occupancy most nearly resembles, according to the fire safety and relative hazard involved.

1. Assembly (see Section 303): Groups A-1, A-2, A-3, A-4 and A-5
2. Business (see Section 304): Group B
3. Educational (see Section 305): Group E
4. Factory and Industrial (see Section 306): Groups F-1 and F-2
5. High Hazard (see Section 307): Groups H-1, H-2, H-3, H-4 and H-5
6. Institutional (see Section 308): Groups I-1, I-2, I-3 and I-4
7. Mercantile (see Section 309): Group M
8. Residential (see Section 310): Groups R-1, R-2, R-3 and R-4
9. Storage (see Section 311): Groups S-1 and S-2
10. Utility and Miscellaneous (see Section 312): Group U

#### SECTION 303 ASSEMBLY GROUP A

**303.1 Assembly Group A.** Assembly Group A occupancy includes, among others, the use of a building or structure, or a portion thereof, for the gathering of persons for purposes such as civic, social or religious functions; recreation, food or drink consumption or awaiting transportation.

##### Exceptions:

1. A building or tenant space used for assembly purposes with an *occupant load* of less than 50 persons shall be classified as a Group B occupancy.

2. A room or space used for assembly purposes with an *occupant load* of less than 50 persons and accessory to another occupancy shall be classified as a Group B occupancy or as part of that occupancy.
3. A room or space used for assembly purposes that is less than 69.5 m<sup>2</sup> in area and accessory to another occupancy shall be classified as a Group B occupancy or as part of that occupancy.
4. Assembly areas that are accessory to Group E occupancies are not considered separate occupancies except when applying the assembly occupancy requirements of Chapter 11.
5. Accessory religious educational rooms and religious auditoriums with occupant loads of less than 100 are not considered separate occupancies.

Assembly occupancies shall include the following:

**A-1** Assembly uses, usually with fixed seating, intended for the production and viewing of the performing arts or motion pictures including, but not limited to:

Motion picture theaters  
Symphony and concert halls  
Television and radio studios admitting an audience  
Theaters

**A-2** Assembly uses intended for food and/or drink consumption including, but not limited to:

Banquet halls  
Night clubs  
Restaurants  
Taverns and bars

**A-3** Assembly uses intended for worship, recreation or amusement and other assembly uses not classified elsewhere in Group A including, but not limited to:

Amusement arcades  
Art galleries  
Bowling alleys  
Community halls  
Courtrooms  
Dance halls (not including food or drink consumption)  
Exhibition halls  
Funeral parlors  
Gymnasiums (without spectator seating)  
Indoor swimming pools (without spectator seating)  
Indoor tennis courts (without spectator seating)  
Lecture halls  
Libraries  
Museums  
Places of religious worship  
Pool and billiard parlors  
Waiting areas in transportation terminals

#### USE AND OCCUPANCY CLASSIFICATION

**A-4** Assembly uses intended for viewing of indoor sporting events and activities with spectator seating including, but not limited to:

Arenas  
Skating rinks  
Swimming pools  
Tennis courts

**A-5** Assembly uses intended for participation in or viewing outdoor activities including, but not limited to:

Amusement park structures  
Bleachers  
Grandstands  
Stadiums

#### SECTION 304 BUSINESS GROUP B

**304.1 Business Group B.** Business Group B occupancy includes, among others, the use of a building or structure, or a portion thereof, for office, professional or service-type transactions, including storage of records and accounts. Business occupancies shall include, but not be limited to, the following:

Airport traffic control towers  
Ambulatory health care facilities  
Animal hospitals, kennels and pounds  
Banks  
Barber and beauty shops  
Car wash  
Civic administration  
Clinic—outpatient  
Dry cleaning and laundries: pick-up and delivery stations and self-service  
Educational occupancies for students above the 12th grade  
Electronic data processing  
Laboratories: testing and research  
Motor vehicle showrooms  
Post offices  
Print shops  
Professional services (architects, attorneys, dentists, physicians, engineers, etc.)  
Radio and television stations  
Telephone exchanges  
Training and skill development not within a school or academic program

**304.1.1 Definitions.** The following words and terms shall, for the purposes of this section and as used elsewhere in this code, have the meanings shown herein.

**CLINIC, OUTPATIENT.** Buildings or portions thereof used to provide medical care on less than a 24-hour basis to individuals who are not rendered incapable of self-preservation by the services provided.

#### SECTION 305 EDUCATIONAL GROUP E

**305.1 Educational Group E.** Educational Group E occupancy includes, among others, the use of a building or structure, or a

portion thereof, by six or more persons at any one time for educational purposes through the 12th grade. Religious educational rooms and religious auditoriums, which are accessory to *places of religious worship* in accordance with Section 303.1 and have *occupant loads* of less than 100, shall be classified as Group A-3 occupancies.

**305.2 Day care.** The use of a building or structure, or portion thereof, for educational, supervision or *personal care services* for more than five children older than 2½ years of age, shall be classified as a Group E occupancy.

#### SECTION 306 FACTORY GROUP F

**306.1 Factory Industrial Group F.** Factory Industrial Group F occupancy includes, among others, the use of a building or structure, or a portion thereof, for assembling, disassembling, fabricating, finishing, manufacturing, packaging, repair or processing operations that are not classified as a Group H hazardous or Group S storage occupancy.

**306.2 Factory Industrial F-1 Moderate-hazard Occupancy.** Factory industrial uses which are not classified as F-1 Moderate Hazard and shall include, but not be limited to, the following:

Aircraft (manufacturing, not to include repair)  
Appliances  
Athletic equipment  
Automobiles and other motor vehicles  
Bakeries  
Beverages: over 16-percent alcohol content  
Bicycles  
Boats  
Brooms or brushes  
Business machines  
Cameras and photo equipment  
Canvas or similar fabric  
Carpets and rugs (includes cleaning)  
Clothing  
Construction and agricultural machinery  
Disinfectants  
Dry cleaning and dyeing  
Electric generation plants  
Electronics  
Engines (including rebuilding)  
Food processing  
Furniture  
Hemp products  
Jute products  
Laundries  
Leather products  
Machinery  
Metals  
Millwork (sash and door)  
Motion pictures and television filming (without spectators)  
Musical instruments  
Optical goods  
Paper mills or products  
Photographic film

## Abu Dhabi International Building Code:

### Exceptions:

1. A single step with a maximum riser height of 180 mm is permitted for buildings with occupancies in Groups F, H, R-2, R-3, S and U at exterior doors not required to be accessible by Chapter 11.
2. A stair with a single riser or with two risers and a tread is permitted at locations not required to be accessible by Chapter 11, provided that the risers and treads comply with Section 1009.4, the minimum depth of the tread is 330 mm and at least one *handrail* complying with Section 1012 is provided within 760 mm of the centerline of the normal path of egress travel on the stair.
3. A step is permitted in aisles serving seating that has a difference in elevation less than 305 mm at locations not required to be accessible by Chapter 11, provided that the risers and treads comply with Section 1028.11 and the aisle is provided with a *handrail* complying with Section 1028.13.

Throughout a story in a Group I-2 occupancy, any change in elevation in portions of the *exit access* that serve nonambulatory persons shall be by means of a *ramp* or sloped walkway.

**1003.6 Means of egress continuity.** The path of egress travel along a *means of egress* shall not be interrupted by any building element other than a *means of egress* component as specified in this chapter. Obstructions shall not be placed in the required width of a *means of egress* except projections permitted by this chapter. The required capacity of a *means of egress* system shall not be diminished along the path of egress travel.

**1003.7 Elevators, escalators and moving walks.** Elevators, escalators and moving walks shall not be used as a component of a required *means of egress* from any other part of the building.

**Exception:** Elevators used as an *accessible means of egress* in accordance with Section 1007.4.

### SECTION 1004 OCCUPANT LOAD

**1004.1 Design occupant load.** In determining *means of egress* requirements, the number of occupants for whom *means of egress* facilities shall be provided shall be determined in accordance with this section. Where occupants from accessory areas egress through a primary space, the calculated *occupant load* for the primary space shall include the total *occupant load* of the primary space plus the number of occupants egressing through it from the accessory area.

**1004.1.1 Areas without fixed seating.** The number of occupants shall be computed at the rate of one occupant per unit of area as prescribed in Table 1004.1.1. For areas without fixed seating, the *occupant load* shall not be less than that number determined by dividing the floor area under consideration by the occupant per unit of area factor assigned to the occupancy as set forth in Table 1004.1.1. Where an intended use is not listed in Table 1004.1.1, the

*building official* shall establish a use based on a listed use that most nearly resembles the intended use.

**Exception:** Where *approved* by the *building official*, the actual number of occupants for whom each occupied space, floor or building is designed, although less than those determined by calculation, shall be permitted to be used in the determination of the design *occupant load*.

**1004.2 Increased occupant load.** The *occupant load* permitted in any building, or portion thereof, is permitted to be increased from that number established for the occupancies in Table 1004.1.1, provided that all other requirements of the code are also met based on such modified number and the *occupant load* does not exceed one occupant per 0.65 m<sup>2</sup> of occupiable floor space. Where required by the *building official*, an *approved aisle*, seating or fixed equipment diagram substantiating any increase in *occupant load* shall be submitted. Where required by the *building official*, such diagram shall be posted.

**1004.3 Posting of occupant load.** Every room or space that is an assembly occupancy shall have the *occupant load* of the room or space posted in a conspicuous place, near the main *exit* or *exit access doorway* from the room or space. Posted signs shall be of an *approved* legible permanent design and shall be maintained by the owner or authorized agent.

**1004.4 Exiting from multiple levels.** Where *exits* serve more than one floor, only the *occupant load* of each floor considered individually shall be used in computing the required capacity of the *exits* at that floor, provided that the *exit* capacity shall not decrease in the direction of egress travel.

**1004.5 Egress convergence.** Where *means of egress* from floors above and below converge at an intermediate level, the capacity of the *means of egress* from the point of convergence shall not be less than the sum of the two floors.

**1004.6 Mezzanine levels.** The *occupant load* of a *mezzanine* level with egress onto a room or area below shall be added to that room or area's *occupant load*, and the capacity of the exits shall be designed for the total *occupant load* thus established.

**1004.7 Fixed seating.** For areas having fixed seats and *aisles*, the *occupant load* shall be determined by the number of fixed seats installed therein. The *occupant load* for areas in which fixed seating is not installed, such as waiting spaces and *wheel-chair spaces*, shall be determined in accordance with Section 1004.1.1 and added to the number of fixed seats.

For areas having fixed seating without dividing arms, the *occupant load* shall not be less than the number of seats based on one person for each 455 mm of seating length.

The *occupant load* of seating booths shall be based on one person for each 610 mm of booth seat length measured at the backrest of the seating booth.

**1004.8 Outdoor areas.** Yards, patios, courts and similar outdoor areas accessible to and usable by the building occupants shall be provided with *means of egress* as required by this chapter. The *occupant load* of such outdoor areas shall be assigned by the *building official* in accordance with the anticipated use. Where outdoor areas are to be used by persons in addition to the occupants of the building, and the path of egress travel from the outdoor areas passes through the building, *means of egress*

TABLE 1004.1.1  
MAXIMUM FLOOR AREA ALLOWANCES PER OCCUPANT

FUNCTION OF SPACE	FLOOR AREA (square meters per person)
Accessory storage areas, mechanical equipment room	28 gross
Agricultural building	28 gross
Aircraft hangars	46.5 gross
Airport terminal	
Baggage claim	1.85 gross
Baggage handling	28 gross
Concourse	9.3 gross
Waiting areas	1.4 gross
Assembly	
Gaming floors (keno, slots, etc.)	1 gross
Assembly with fixed seats	See Section 1004.7
Assembly without fixed seats	
Concentrated (chairs only—not fixed)	0.65 net
Standing space	0.465 net
Mosque/Masjid	0.7 m <sup>2</sup>
Unconcentrated (tables and chairs)	1.4 net
Bowling centers, allow 5 persons for each lane including 4,550 m of runway, and for additional areas	0.65 net
Business areas	9.3 gross
Courtrooms—other than fixed seating areas	3.7 net
Day care	3.25 net
Dormitories	4.65 gross
Educational	
Classroom area	1.85 net
Shops and other vocational room areas	4.65 net
Exercise rooms	4.65 gross
H-5 Fabrication and manufacturing areas	18.5 gross
Industrial areas	9.3 gross
Institutional areas	
Inpatient treatment areas	22.5 gross
Outpatient areas	9.3 gross
Sleeping areas	11 gross
Kitchens, commercial	18.5 gross
Library	
Reading rooms	4.65 net
Stack area	9.3 gross
Locker rooms	4.65 gross
Mercantile	
Areas on other floors	5.55 gross
Basement and grade floor areas	2.8 gross
Storage, stock, shipping areas	28 gross
Parking garages	18.5 gross
Residential	18.5 gross
Skating rinks, swimming pools	
Rink and pool	4.65 gross
Decks	1.40 gross
Stages and platforms	1.4 net
Warehouses	46.5 gross



3

# Population Density





# Population Density

An integrated sports community facility for men and women is established if the population density of the area ranges between 25,000 to 35,000 people, according to the Community Facilities Planning Guide of the Department of Municipalities and Transport.

## معايير تخطيط المرافق المجتمعية في إمارة أبوظبي

معايير تخطيط المرافق المجتمعية

جدول PS15، (يتبع) متطلبات المرافق المجتمعية - مركز منطقة

جميع أنواع السياقات العمرانية				ريفي		ضواحي		حضري		نوع المرفق	
الجهة المعنية	المتطلبات الإضافية الأخرى	الحد الأقصى للقدرة الاستيعابية للمرفق	نطاق الترخيم (المسافة)	نطاق الترخيم (السكان)	الحد الأدنى للمساحة الكلية (متر مربع)	الحد الأدنى للمساحة القسمة (متر مربع)	الحد الأدنى للمساحة الكلية (متر مربع)	الحد الأدنى للمساحة القسمة (متر مربع)	الحد الأدنى للمساحة الكلية (متر مربع)		الحد الأدنى للمساحة القسمة (متر مربع)
مجلس أبوظبي الرياضي				25,000 إلى 35,000 نسمة.	6,500	19,500	6,500	19,500	9,300	16,800	مركز رياضي (موقع غير مقيد) <sup>4</sup>
				<b>أو</b> <sup>5</sup>							
مجلس أبوظبي الرياضي				35,000 إلى 25,000 نسمة.					- 10,400 15,800	- 13,200 20,000	مركز رياضي (موقع مقيد) <sup>10</sup>

<sup>4</sup> تم تحديد متطلبات المركز الرياضي للموقع (الحضري) غير المقيد متعدد الاستخدامات ليشمل مركزاً رياضياً داخلياً وأربعة مساحات للألعاب متعددة الاستخدامات وملعباً كبيراً واحداً. يعد المركز الرياضي (موقع مقيد) اختياراً يشار إليه بـ "أو" في الجدول. يمكن لمفتريات المخططات العامة في المناطق الحضرية استخدامه. يجب على المطور اختيار الحل الأنسب لمفتوح المخطط العام.

<sup>5</sup> بالنسبة للمراكز الرياضية، هناك خيار للحجم. لا ينطبق خيار "الموقع المقيد" إلا في المناطق الحضرية، حيث تتوفر مساحة محدودة من الأراضي بينما يمكن استخدام خيار "الموقع غير المقيد" في سياقات المناطق الريفية والضواحي بالإضافة إلى المناطق الحضرية، حيث تتوفر مساحات الأراضي الكافية.

<sup>10</sup> تم تحديد متطلبات المركز الرياضي للموقع (الحضري) المقيد متعدد الطوابق ليشمل مركزاً رياضياً داخلياً، ومساحة للألعاب متعددة الاستخدامات.

تشير الخانات المظللة باللون الرمادي إلى عدم وجود معايير أو إرشادات متاحة للإشارة إليها.

تشير الخانات المظللة باللون الأزرق إلى أن نوع أو حجم المرفق المجتمعي غير مستحسن في هذا السياق العمراني.



## 4

## Sports Facilities Planning Phases

### Sports Facilities Planning Phases

Planning for a sports facility is an indispensable necessity, whether it is for the purpose of a new facility or for adding a part or parts to an existing facility. Planning includes all the necessary procedures by which the desired situation can be reached in the future. Since this work is related to a facility that serves the field of sports, the Abu Dhabi Sports Council has a major role in all planning processes, which mostly depend on the size of the sports facility to be established.

### The following points explain the stages of planning a sports facility:

1. Proposed project idea
2. Studying the sites of lands allocated for the implementation of sports projects and choosing the site according to its intended purpose.
3. Formulate the initial idea as basic points, requirements, design ideas, target audience, type of events, and capacity for each facility, as will be explained later.
4. Preparing studies, technical plans, and economic feasibility studies for the project
5. Estimating the financial cost of the project
6. Appointing the appropriate design consultant, whose most important characteristics are: To be authorized to practice the profession, to have the ability to innovate, to have previous experience in designing sports facilities and to be familiar with the specifications and building rules in the Emirate and as required by the specifics of the sports game.
7. Choosing the consulting office to supervise the project in the implementation phase, which in turn provides technical advice

## Sports stadium design stage:

Closed facilities	Open/outdoor playgrounds
<b>Walls</b>	
<ul style="list-style-type: none"> <li>Walls / sound, echo, light and heat insulators must be used to separate some designated areas depending on use</li> <li>Walls with moisture and rust resistant and soundproof surfaces must be chosen for changing rooms, toilets and shower rooms.</li> <li>Separation of toilets from shower rooms</li> <li>Meeting and lecture rooms must be of high quality in sound insulation</li> </ul>	<ul style="list-style-type: none"> <li>Homogeneous playgrounds must be close to each other in order to facilitate the process of controlling their management and maintenance work.</li> <li>Service facilities such as changing rooms, toilets, showers and administration buildings must be close to the playgrounds</li> </ul>
<b>Ceilings</b>	
<ul style="list-style-type: none"> <li>The construction and design of the roof of the gym depends on the size of the facility and the type of sports activity</li> </ul>	
<b>Sports facilities floors</b>	
<ul style="list-style-type: none"> <li>The floor specifications must conform to the minimum specifications and standards related to quality, the degree of light reflection, and the degree of bounce of the ball.</li> </ul> <p>There are three types of floors used in halls:</p> <ul style="list-style-type: none"> <li>Floors for service areas: Moisture, rust and slip resistant floors are required</li> <li>Lecture and meeting rooms, offices and corridors: It can be used on surfaces such as carpets, tiles, cement....etc</li> <li>Grounds for sports activities (playgrounds): Require wooden or synthetic surfaces</li> </ul> <p>Types of artificial floors/surfaces in indoor courts include:</p> <ul style="list-style-type: none"> <li>(PVC'S) Plasticized Polyvinyl Chlorides, pre-assembled and manufactured</li> <li>Polyurethanes</li> </ul> <p>Football playgrounds floors</p> <ul style="list-style-type: none"> <li>Artificial grass : In accordance with health and safety standards</li> </ul>	<ul style="list-style-type: none"> <li>There is no single type of flooring/surface that fits and suits all the needs of outdoor activities. Each floor activity has conditions and specifications, on the basis of which the quality of materials is chosen.</li> <li><b>In order to choose the floor of the outdoor playgrounds, the following points must be taken into account:</b></li> <li>Versatility in use / durability and endurance / resistance to sun and rain, dust and rust / lack of roughness / ease of maintenance / beauty of appearance / flexibility / cost</li> <li><b>The method used to evaluate artificial surfaces includes the following points:</b></li> <li>Basic cost / maintenance and repair cost / durability and endurance / friction / shock absorption / flexibility and quality preservation / suitability for use / stretch and tensile resistance / color fastness / susceptibility to heat and sun</li> <li><b>Football playgrounds floors</b></li> <li>Natural grass: In conformity with the specifications of the International Federation - FIFA</li> <li>Artificial grass : In accordance with health and safety standards</li> </ul>
<b>Doors</b>	
<ul style="list-style-type: none"> <li>Taking into account the size of the doors to allow the entry of heavy equipment and vehicles (as needed).</li> </ul>	

Closed Facilities	Open/outdoor playgrounds
<b>Ventilation</b>	
<ul style="list-style-type: none"> <li>The temperature must be commensurate with the practiced activity, and it ranges between 18-23 Celsius in the activity area (and about 24 Celsius for swimming pools, depending on the humidity in the pool) and it may increase slightly in the spectator areas.</li> <li>Ventilation must be of a high quality, allowing for a minimum of 4 air changes per hour</li> <li>Humidity should be commensurate with body temperature, ranging between 40-60%.</li> <li>The air speed should not affect the athletic performance or the direction of the ball, and it should not exceed 1.5 m/min</li> </ul>	<ul style="list-style-type: none"> <li>Natural ventilation, taking into consideration what was previously mentioned in the general principles of site selection</li> </ul>
<b>Chairs and stands</b>	
<ul style="list-style-type: none"> <li><b>Spectator comfort:</b> Each spectator needs a seat with a width ranging between 50-80 cm, preferably with a back</li> <li><b>Good visibility / view:</b> This depends on the distance between the seat and the court, as well as the line of sight (distance between the seat and the center of the court, taking into account the degree of inclination) and the degree of inclination of the sun's rays.</li> </ul> <p>The spectator can see an object with a height of (3 cm) from a distance of approximately (100 m), and maybe more. Therefore, good vision is governed by the size/capacity of the playground (the larger the capacity of the playground, the longer the line of sight) and the type of sport (for example: football is different from tennis.) Although there are many modern engineering designs for stands around sports playgrounds (circular, oval, semi-circular... etc.), however, it is preferable that the maximum distance between the farthest spectator and the middle of the playground floor be less than 100 meters, so that the vision is sound and comfortable, and therefore the width (height) of the stands was reduced to less than 70 cm so that the vision curve is proportional to the height.</p>	
<b>Lighting</b>	
<ul style="list-style-type: none"> <li>Measuring the intensity and degree of lighting distribution throughout the playground floor (for each sport a specific degree of lighting intensity).</li> <li>There are some factors that must be taken into account when choosing an electrical lighting system, including: Maintenance, repair, replacement and cleaning.</li> <li>In closed halls, swimming pools, and the like, lighting sources must be distributed evenly, and it is preferable to add lighting sources in the goal areas or the goal to increase the clarity of vision.</li> <li>Low lighting is preferred in spectator/audience areas</li> <li>In areas with high humidity, such as toilets, showers, swimming pools, etc., moisture-resistant light bulbs are needed.</li> <li>It should also not be directed in a way that affects the players</li> </ul>	<ul style="list-style-type: none"> <li>There are three main factors that should be taken into consideration as follows: Note that the first and second factors affect the quality of lighting and the financial cost, while the third factor is its relationship to practitioners and viewers.</li> <li>Distance: Lighting sources are placed outside the practice areas at different distances, which affects the intensity and quality of lighting</li> <li>Environmental factors: Special lamps to avoid their problems</li> <li>Safety and Security: The connections must be removed from the ground and connected to a separate electrical control unit</li> <li>Measuring the intensity and degree of lighting distribution throughout the playground floor (for each sport a specific degree of lighting intensity).</li> <li>It should also not be directed in a way that affects the players</li> </ul>

# 5

## **Designing a site for practicing sports activity**





# Outdoor Sports |



# 01 Football

## Playground

- The playground on which official matches are held is 105 meters long and 68 meters wide
- The minimum extra space behind the goals (for warm-up, assistant referees, media, etc.) is 8.5m at the sides and 10m at the ends.

## Floor

The types of floors used in football fields differ according to the specific needs of each playground. The following are the types of floors for football playgrounds:

1. Soft and thick natural grass
2. An industrial floor made of plastic or rubber materials.
3. Hybrid floor: It uses natural grass with the addition of some synthetic materials to improve the durability of the grass

## Goal

A rectangular goal is placed in the middle of each goal line, and the distance between the two vertical crossbars must be 7.32 meters, and the height of the horizontal crossbar from the ground is 2.44 meters, which is raised from the ground by the two vertical crossbars.

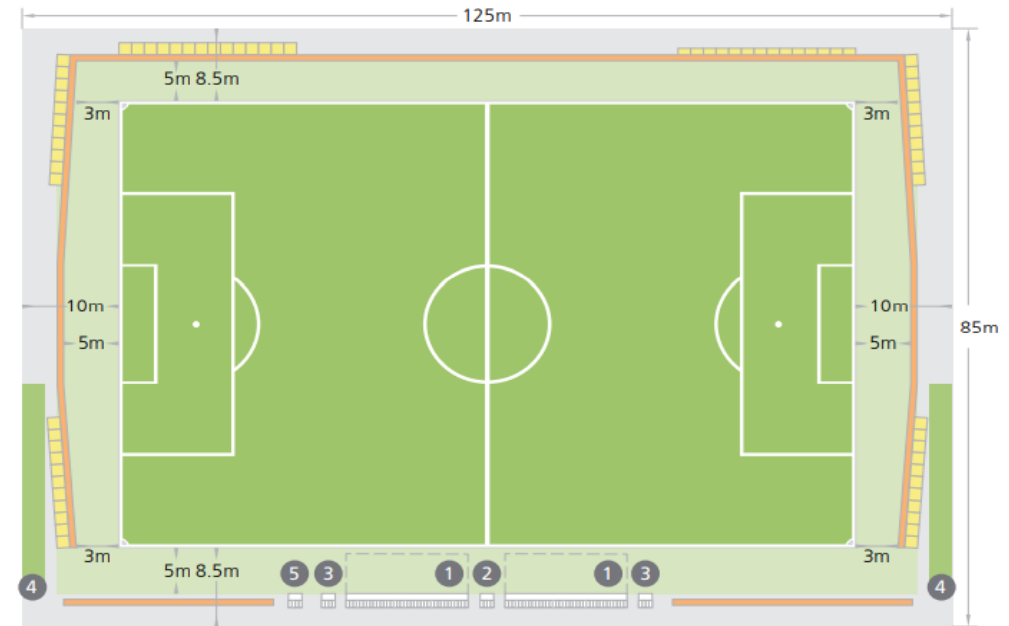
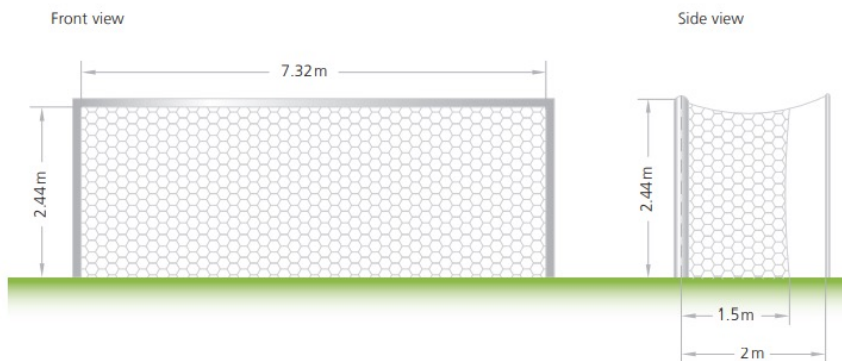

- |                             |                              |
|-----------------------------|------------------------------|
| ① Substitutes' bench        | ■ Field of play – 105 x 68m  |
| ② Fourth official           | ■ Grass area – 115 x 78m     |
| ③ Team medical bench        | ■ Auxiliary area – 125 x 85m |
| ④ Warm-up area              | --- Technical area           |
| ⑤ Reserve assistant referee | — Advertising boards         |
|                             | ■ Photographers' position    |

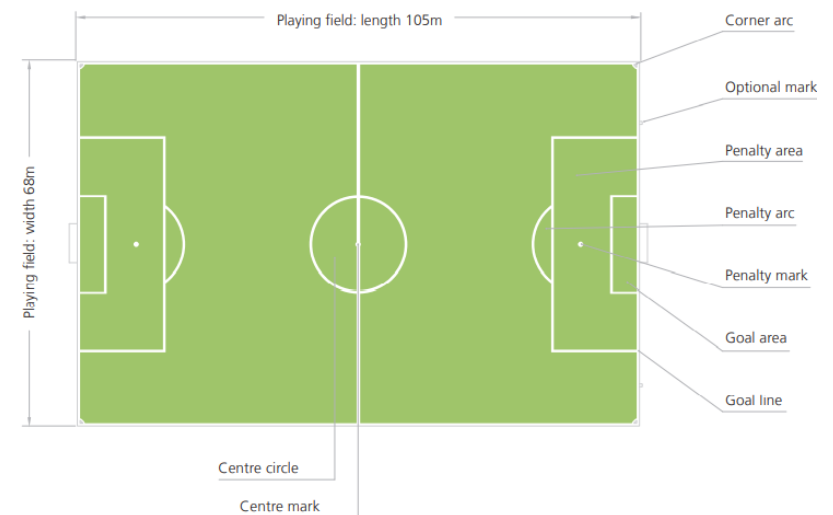

## 02 Football - Beach

### Playground

- The playing area is between 35 and 37 meters long and between 26 and 28 meters wide, and is marked with lines ten centimeters wide.
- The center line is marked with red flags. Another imaginary line marked with yellow flags is nine meters from each goal line. It is the penalty area, and penalties are taken from the middle of this line if there is a foul.
- The substitution areas are located along the touchline, just like in futsal.

### Playground Floor

Football is played on a ground covered with sand to a depth of at least 40 cm

### Goal

A rectangular goal is placed in the middle of each goal line, and the distance between the two vertical crossbars must be 5.5 meters, and the height of the horizontal crossbar from the ground is 2.2 meters, which is raised from the ground by the two vertical crossbars.

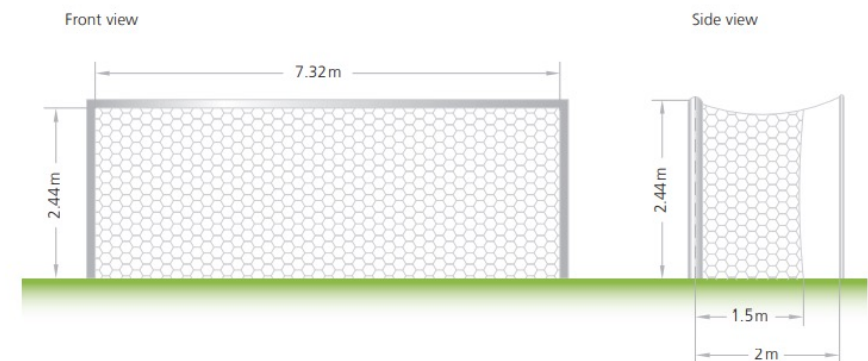
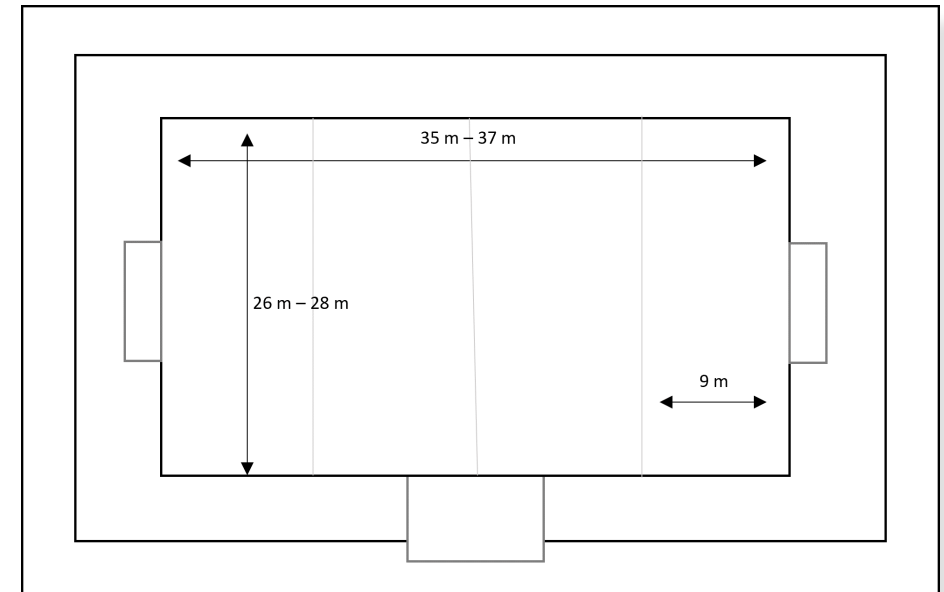



# 03 Tennis

## Playground

The length of the court is 23.77 meters, and the width is 8.23 meters for singles matches and 11 meters for doubles matches. There is a need to additional clear space around the court for players to reach past balls. The length of the tennis court ranges from 35 to 42 meters, while the width ranges from 18 to 21 meters.

## Goal

The net extends across the full width of the playground parallel to the baselines, dividing it into two equal ends. It is fixed either by means of a metal wire, which can be no more than 0.8 cm. The height of the net is 1.07m at the crossbars and 0.91m at the center.

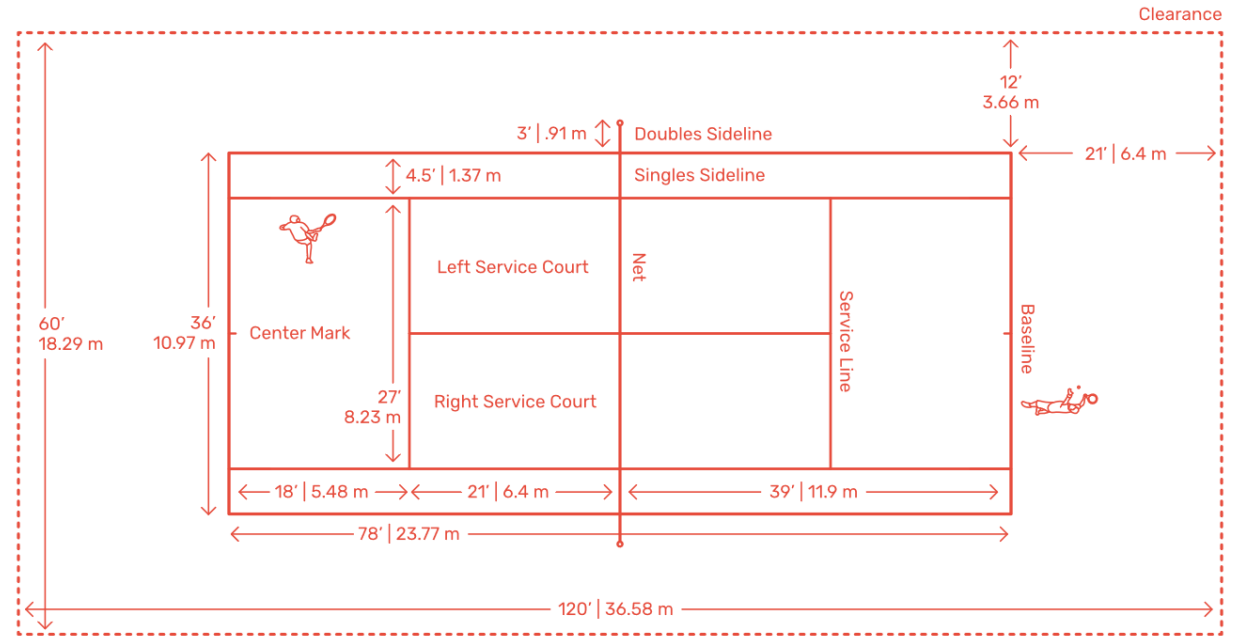

## Floor

The tennis court is made of concrete, mud, grass, or tartan. Concrete is a fast-playing surface, while mud and grass are slow-playing.

Tennis court flooring varies in material depending on indoor or outdoor uses.

Outdoor playgrounds: Made of grass, clay, or acrylic-coated concrete

Indoor playgrounds: Covered with hardwood floors or carpets.

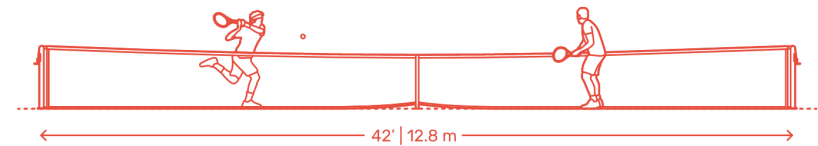
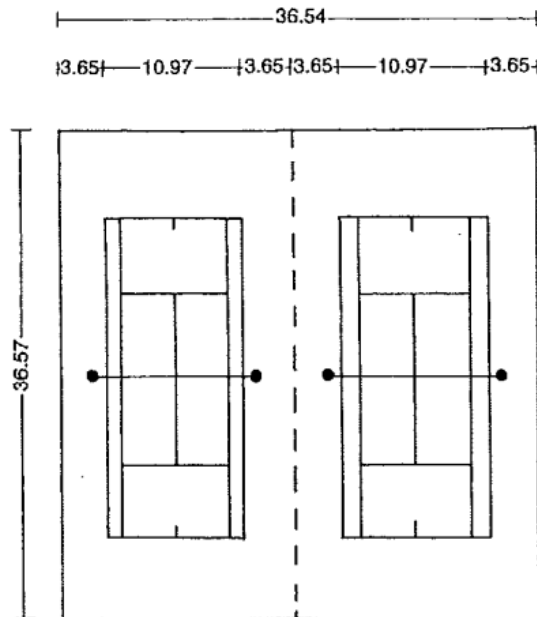

- **Additional measures**
- The side margin is 4 meters
- The posterior margin is 8 meters
- The distance between the two fields is 7.3 meters
- The required height for indoor tennis is from 9-11 meters

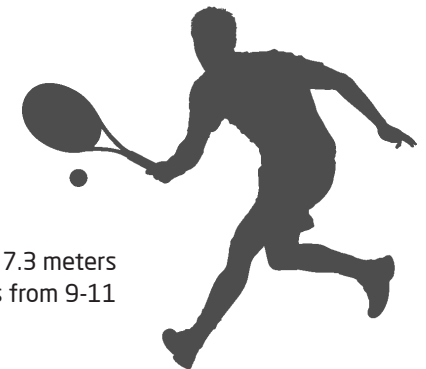

## 04 Paddle Tennis

### Playground

The playground should be a rectangular with a width of 10 meters and a length of 20 meters. In the middle of the playground, there will be a net dividing the field into two parts. It is preferable that there be 1 m surrounding the court from the outside.

### Closed playgrounds:

The ceiling height should not be less than 8 meters, preferably between 9 meters and 10 meters. In addition, the air conditioners are located around the stadium wall.

### Net

The height of the net is 0.88 meters in the middle at a maximum and it rises to 0.92 meters at the sides

### Floor

Synthetic grass of multiple colors, but the common color is the blue color and lined with white lines fixed on double Backing consisting of 100% of synthetic Polypropylene on even solid ground free from defects and the playground should be lined.

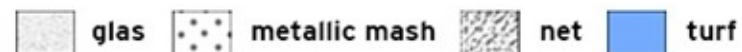
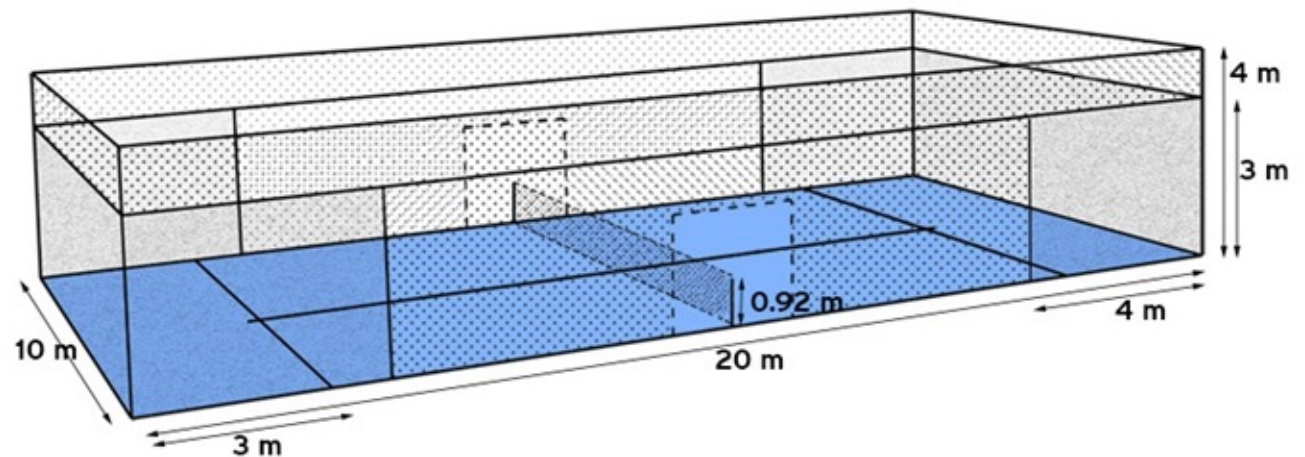
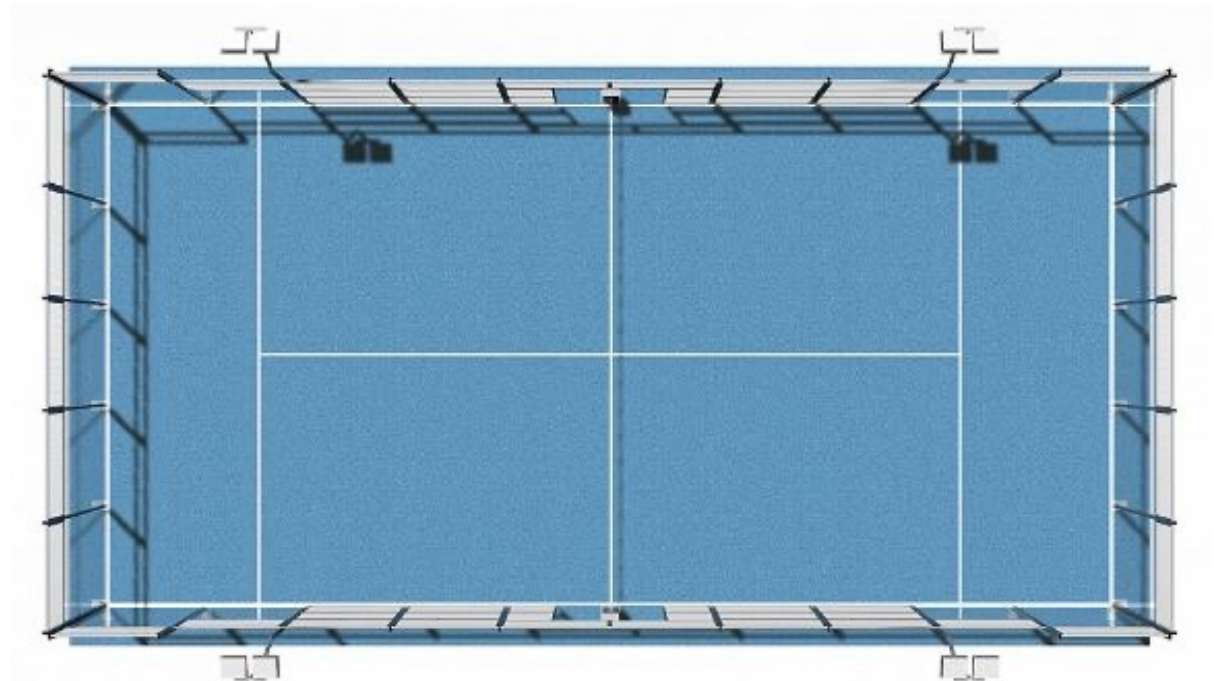





## 06 Track and field

### Running track

The track has straight and curved sections of roughly equal length. The area inside the track is very large to accommodate various events and a football field of international size). (68m x 105m not mandatory if the field is only for athletics)

The track consists of two semicircles with a radius of 36.8 meters each, and straight lines of 84.39 meters each connected to them. (Knowing that there is a 200-meter track, which has half of the measurements mentioned and has only 6 tracks).

The track may contain 8, 6, or 4 tracks, but the four tracks are not used in official international tournaments, as the width of all these tracks is 1.22 meters  $\pm$  0.01 meters, and the materials used in the running track are synthetic rubber or polyurethane.

### Floor

#### • Natural floor

- Most used. They are convenient to operate, relatively cheap to construct, and have minimal impact on runners' joints. These soft surfaces provide excellent cushioning and help reduce injuries. It also creates more resistance than other running track surface materials

- Long-term stable floor performance with high maintenance requirements.

#### • Synthetic floors:

- Rubber particles mixed with latex and polyurethane. Their surface is usually installed about 1/2" deep over an asphalt or concrete base.

- This floor provides great shock absorption, which protects the athletes from injury.

#### • Industrial Vinyl Flooring (PVC):

- The vinyl floor is characterized by shock absorption, high ball bounce, flexibility and optimal sliding rate for sports.

- Vinyl floors are also easy to maintain, versatile and less expensive than other floors.

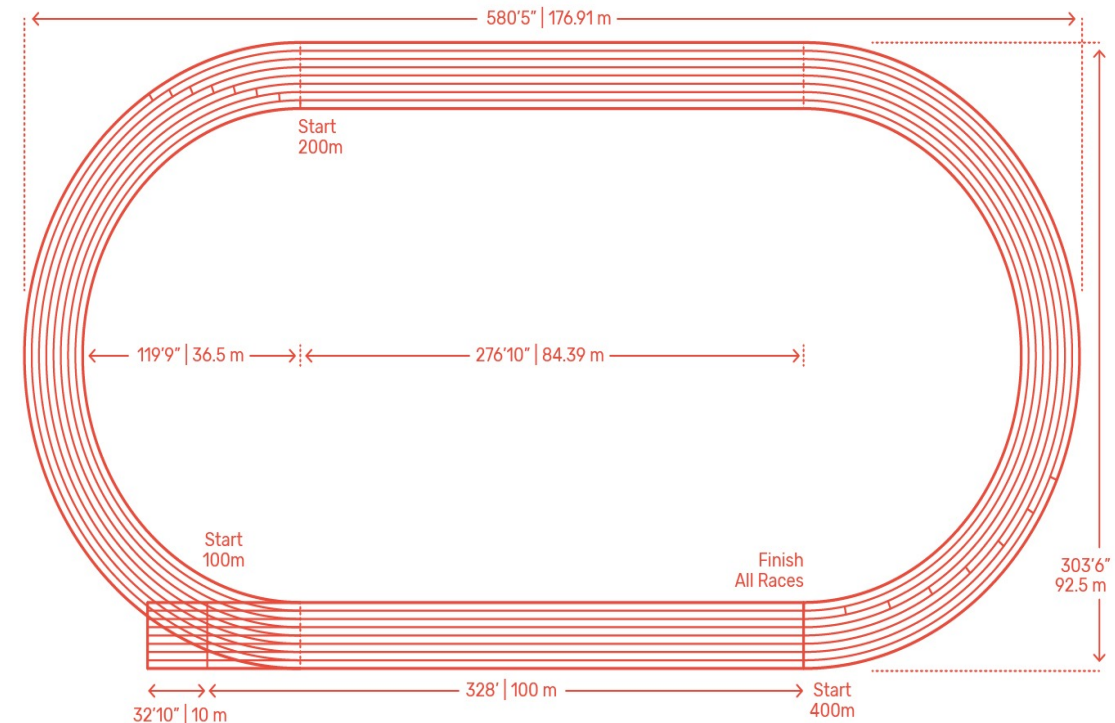

## 07 Cricket

### Playground

A cricket ground encompasses a sizeable circular playing field covered with grass. Within this ground, there are three primary areas, the outfield, infield, and the cricket pitch. The diameter of the cricket ground typically falls within the range of 137 to 152 meters. The cricket pitch, in particular, possesses an overall length of 20.12 meters between the wickets and a playing width of 3.05 meters. In the context of the pitch, the bowling crease has a width of 264 centimetres, while the minimum popping width in front of it measures 366 centimetres. The wicket, which consists of three stumps, is placed 122 centimetres behind the popping crease. Each stump stands at a height of 71.12 centimetres with a width of 22.86 centimetres. Atop these stumps, a pair of bails is positioned, each having a length of 111.13 millimetres and a maximum height above the stump of 12.7 millimetres. For demarcating certain boundaries on the playing field, white lines are drawn using crayons. These lines serve to delineate specific areas of play during the game.

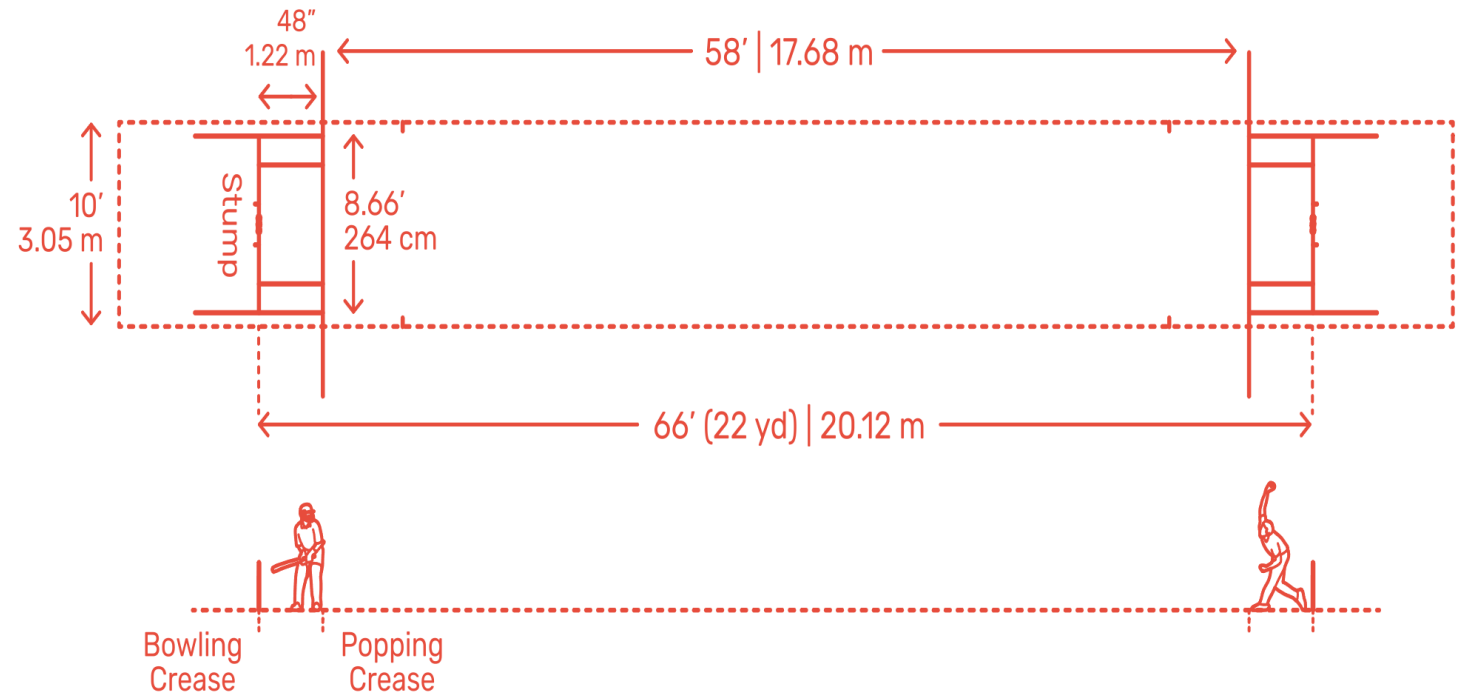

### Floor

The synthetic turf is precisely compacted by measuring the floor in the carpet areas and the course surface is corrected using a maximum 1 ton roller to obtain a smooth surface. Since there are no bumps in the ground, it is easy to play cricket professionally on synthetic grass pitches



# 08 Equestrian

## Playground

A sandy, flat and level arena of 20 x 40m and 20 x 60m which are generally the most common sizes as the picture indicates the inner part of the arena which are the two standard dimensions for dressage tests, which must be separated from the crowd by a distance of ten meters (10 meters) at least. Limiters shall be provided to be placed around the yards approximately 50 cm from the panels. The difference in height across the diameter or along the length of the arena shall not in any case exceed sixty centimeters (60 cm) and the difference in height along the short side of the arena should not exceed twenty centimeters (20 cm).

## Floor

Sandy and flat area.

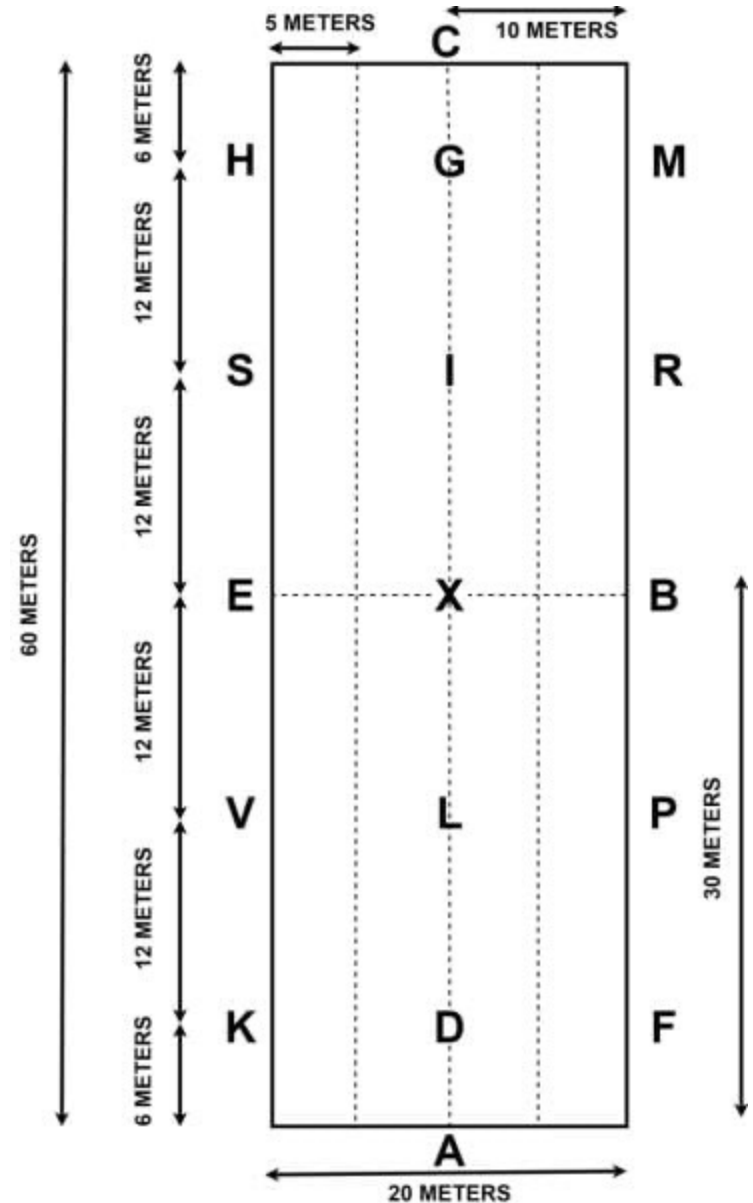
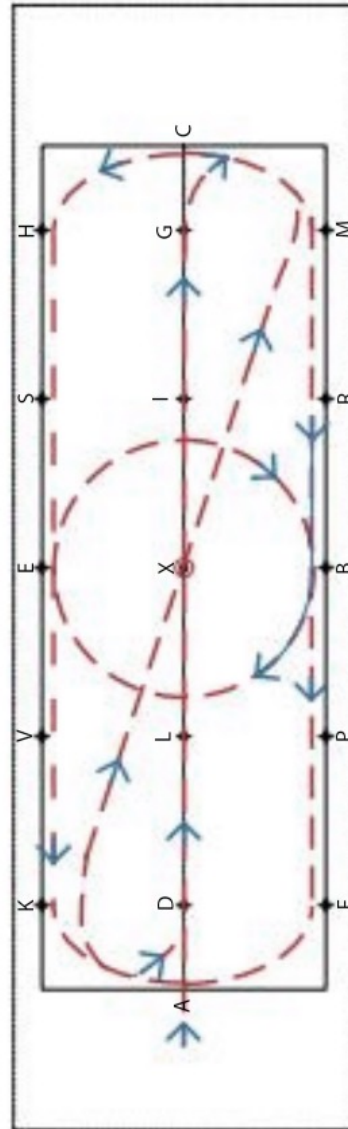

## 09 Showjumping

### Playground

The arena area is at least 30 x 50m and it will fit as well as 30 x 60m which is a great versatile size to ride in - big enough for a dressage test too, and there is no maximum field size.

Obstacle Equipment: Build 32 jumps (50% vertical fence and 50% obstacle spread) and spare obstacle equipment. With a water jump of a maximum width of 4 meters, including the take-off element.

### Floor

Sandy and flat area

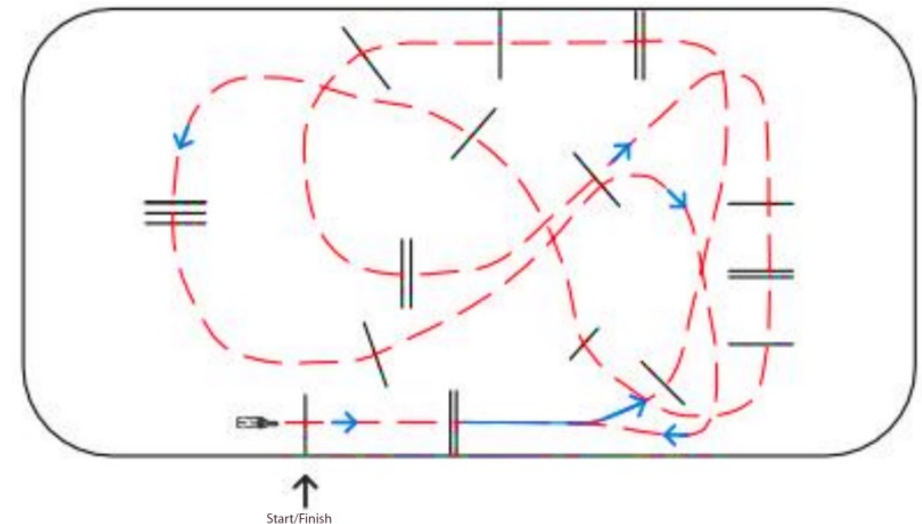
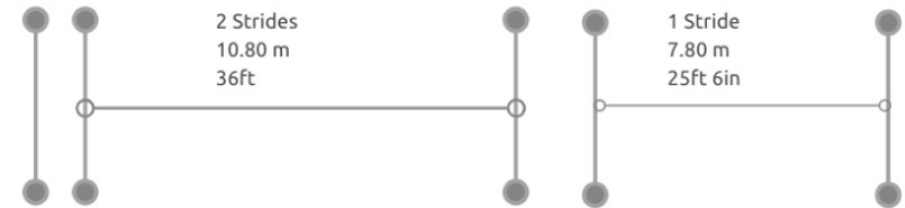



# 10 Falconry



## Falconry field dimensions

Falconry competitions are concerned with the ability and speed of the falcons to snatch and catch the prey. Therefore, the field must be sufficient to ensure the continuity of the falcon in flight as long as the speed of the falcon in competitions exceeds 60 km / h. Therefore, for the safety of the falcon, the field must be completely empty and long enough for the safety of the falcon and the safety of the falconer. . The distance in which the falcons compete within the rules of the competition is (400 meters). Therefore, the dimensions of the falcons arena are approximately 800 meters long from the start and the tent of the participants that is equipped for the falcons to launch and prepare it to the finish line and beyond from a field completely emptied of any barriers or wires or any other obstacles, with a width of about 400 meters, and this is enough from the start to the end of the race.

Of course, all of this is in the general racing field, but there are additional training fields with smaller dimensions, where the training fields are dimensions (250 \* 100) meters with solid floors and in a flat manner as well.

## Floor

The floor of the racing field shall be formed completely (400 \* 800) of sand saturated with water in order to avoid dust.

It is preferable that it be well-packed sabbah sand and have a solid floor free of stones, obstacles and any things that affect the falcon, especially since the falcon flies at a height that almost touches the ground of the field with its wings. The lower the falcon flies, the lower the air resistance and the faster it is, and this is the falconer's ability to train and tame the falcon from flying at lower heights than the natural one that the falcon used to fly. Therefore, the entire floor of the field is sprayed with water on each day of the competitions, and the floor is confirmed to be compacted before the competitions and paved before the season.

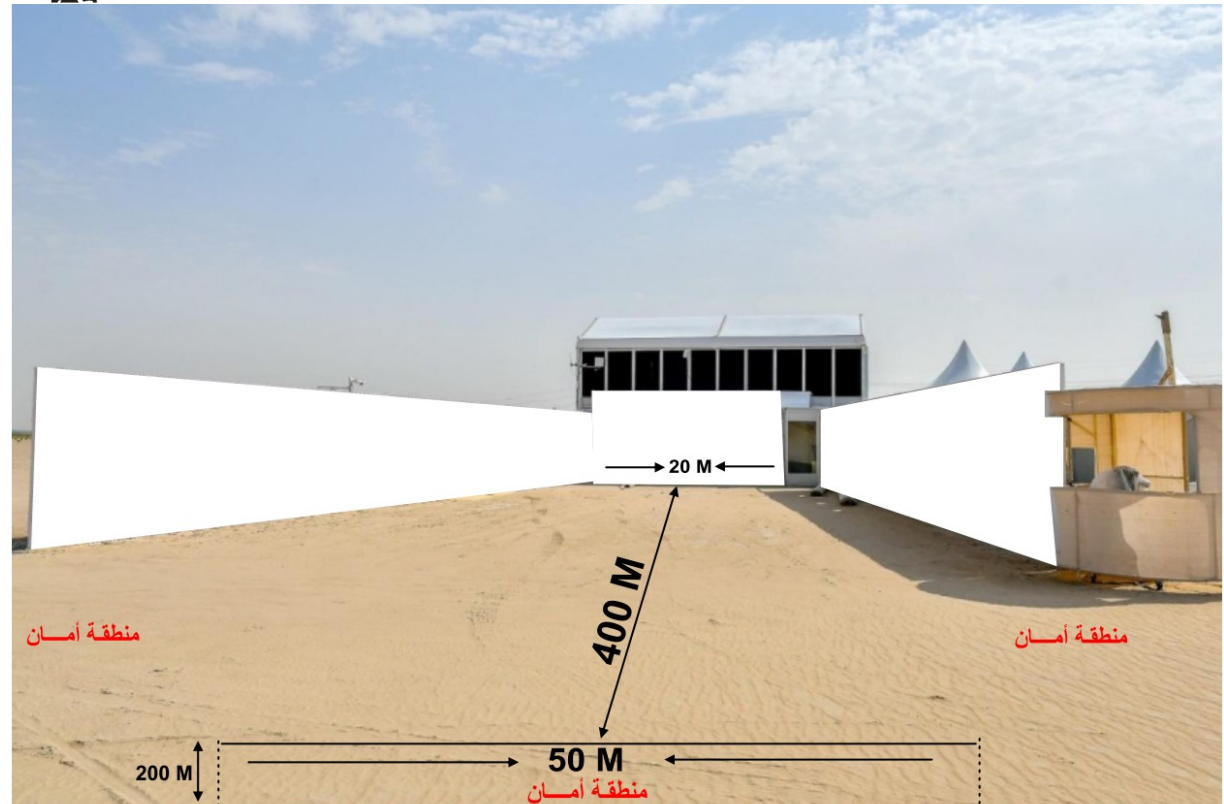





Indoor  
Sports |



# 01 Basketball

## Playground

A basketball court is a rectangular surface usually made of polished hardwood. The playground comes in different shapes and sizes. The playground is 28 meters long, 15 meters wide, and the stadium roof is 8 meters high.

## Goal

The basket is 3.05 meters above the ground and is suspended on rectangular backboards



## Floor

There are two types of basketball courts, each of which differs from the other mostly in the material from which the court floor is made. There are indoor courts that we find in sports halls and their floors are made of solid wood, and the other type is the outdoor courts that are in gatherings and recreational facilities and whose floors are made of asphalt material.

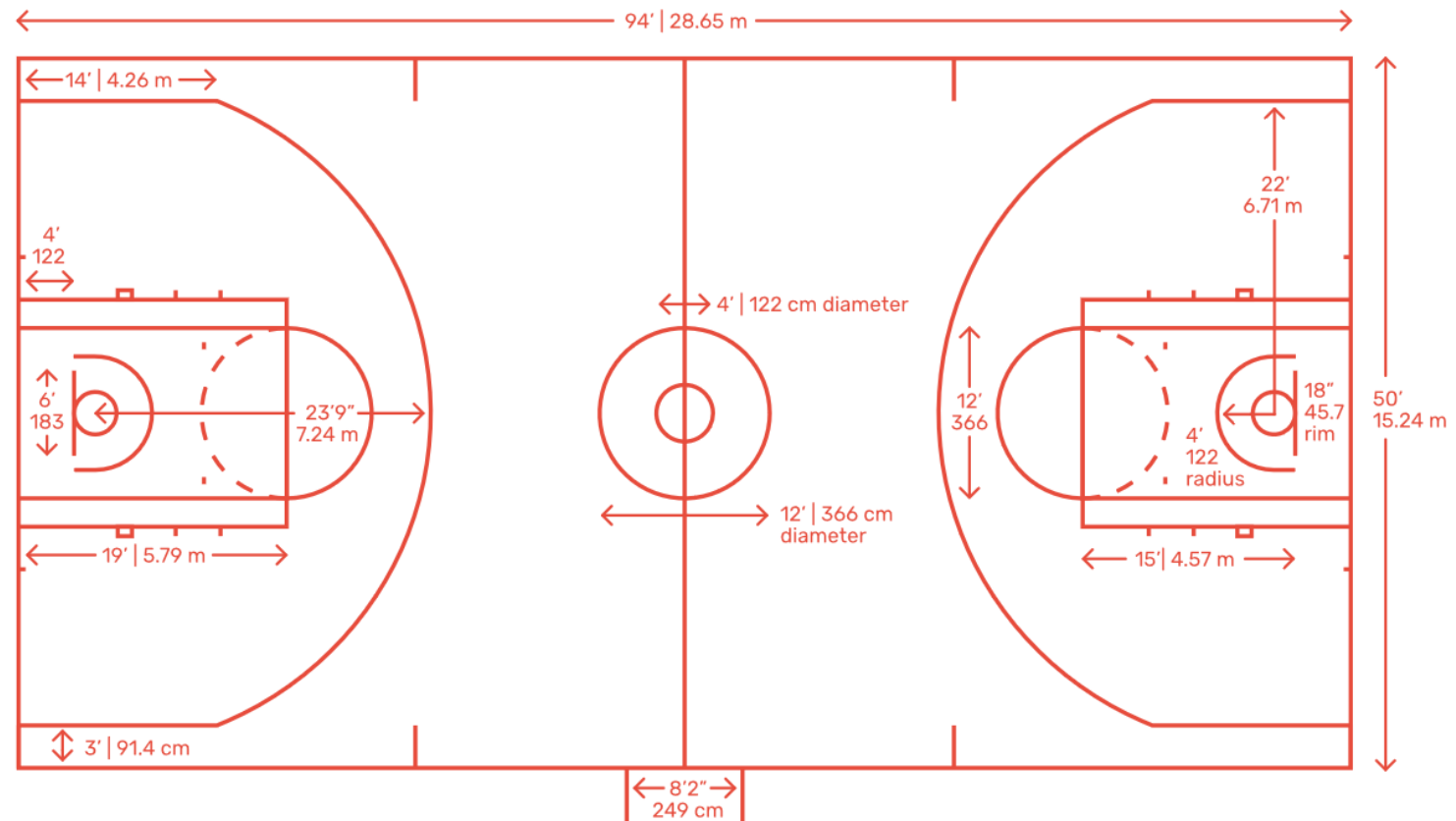



## 02 Triple Basketball

### Playground

Triple basketball is played on a 3x3 court with one basket. The playing field is 15m wide and 11m long. Half of a traditional basketball court can be used to play it. Also, the free throw line (5.80 m), and the arc line of radius (6.75 m) are measured from the point on the ground below the exact center of the opponent's basket to the outer edge of the arc. The "no drawing semicircle" area is below the basket. The distance of the point on the ground from the inner edge of the middle point of the finish line is 1.6 m.

### Floor

#### Polypropylene floor

The polypropylene floor is smooth and slip-resistant.

Long-term stable floor performance with low maintenance requirements.

The ball bounce rate is 100%.

#### Solid wood floors:

The hardwood floors contribute to the ball's high bounce rate of 100%.

It can be maintained quite easily compared to other floors.

Wood floors provide a flat, uniform playing surface for athletes.

#### Industrial Vinyl Flooring (PVC):

The vinyl floor is characterized by shock absorption, high ball bounce, flexibility and optimal sliding rate for sports.

Vinyl floors are also easy to maintain, versatile and less expensive than other floors.

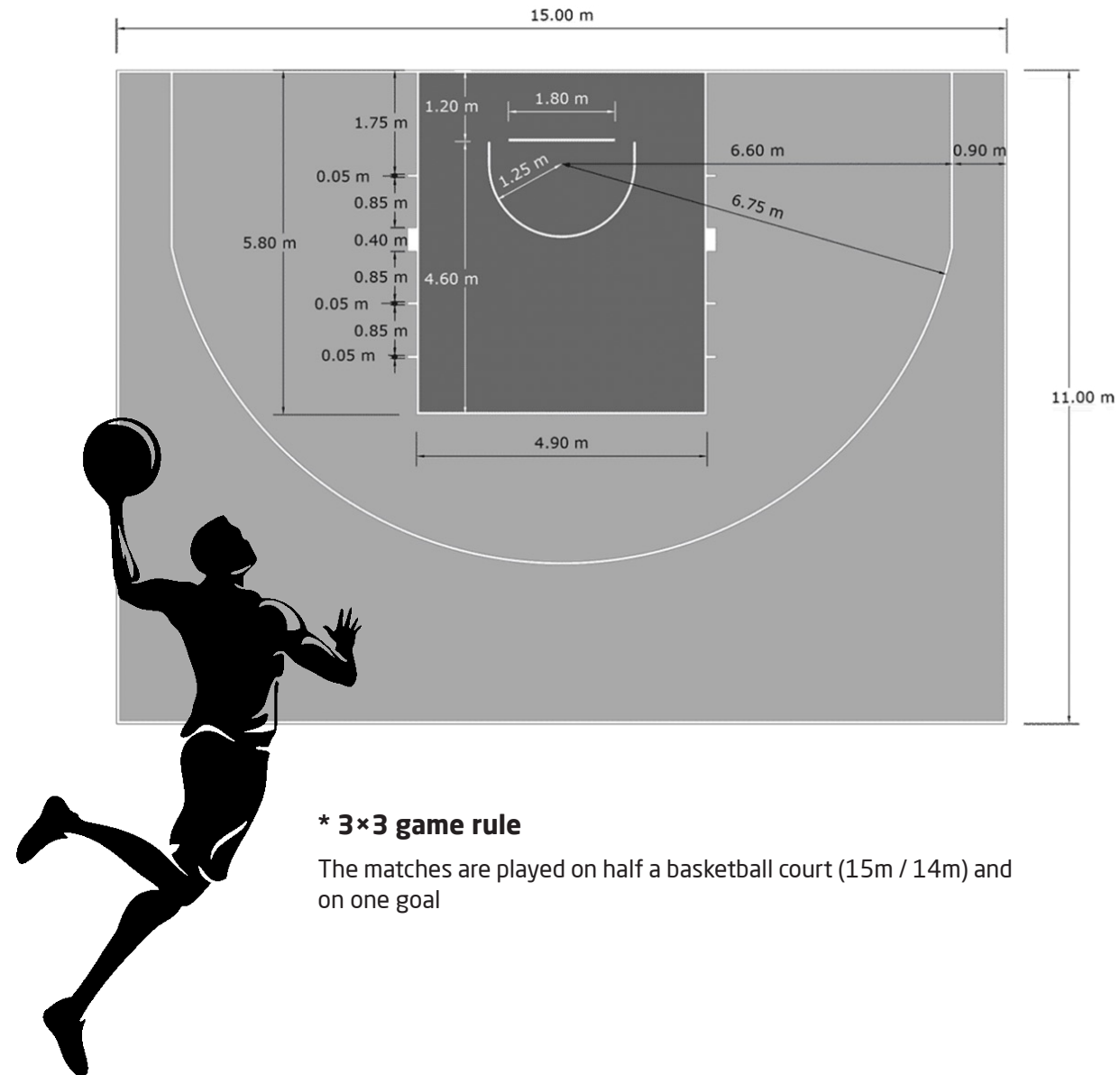

#### \* 3x3 game rule

The matches are played on half a basketball court (15m / 14m) and on one goal

## 03 Volleyball

### Playground

Rectangular in shape, eighteen meters long and nine meters wide, its land is planned with clear lines 5 cm wide. It is preferable to play volleyball in a closed hall, the height of the ceiling of which is not less than seven meters and may reach 12.5 meters, according to the specifications of the International Volleyball Federation regarding the World Cup and Olympic Games. .

To protect the players, there must be an empty space around the court of up to 5 meters (5 meters on the side of the court and 3 meters on the side of the length of the court).

### Floor

The playground floor is usually made of wood or synthetic materials but any non-injurious surface can be used. The floors of the closed playgrounds must be flat, while the floors of the outdoor stadiums must have slight inclinations and slopes for the drainage process.

### Acrylic floor

Quick drying, UV resistant, suitable for indoor and outdoor volleyball court applications. The acrylic floor can be used in the form of 2mm or 3mm. The Acrylic System consists of an acrylic modified filler or rubber powder filled, backer, textured surface, acrylic primer, and acrylic paint finishes.

### Tartan floor

The system consists of two layers with the feature of water permeability, EPDM layer on top, and SBR granular layer on the bottom. The granular layers are hot mixed with a substance called binder. Tartan floor is usually used in the form of 8mm + 5mm. A machine called the Finisher is used on the EPDM and SBR granules hot in the place.

### Solid wood floor

It enables energy recovery, reduction of energy consumption, and engineering needs to be met by bouncing the ball.

### Net

It is nine and a half meters long and one meter wide, on both sides of which are two fiberglass columns. The length of the column is 2.8 meters, and the height of the net is 2.4 meters for men and 2.2 meters for women.

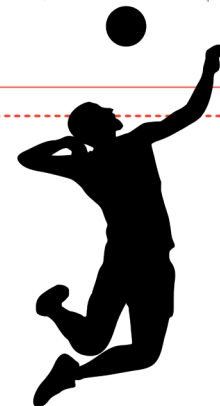
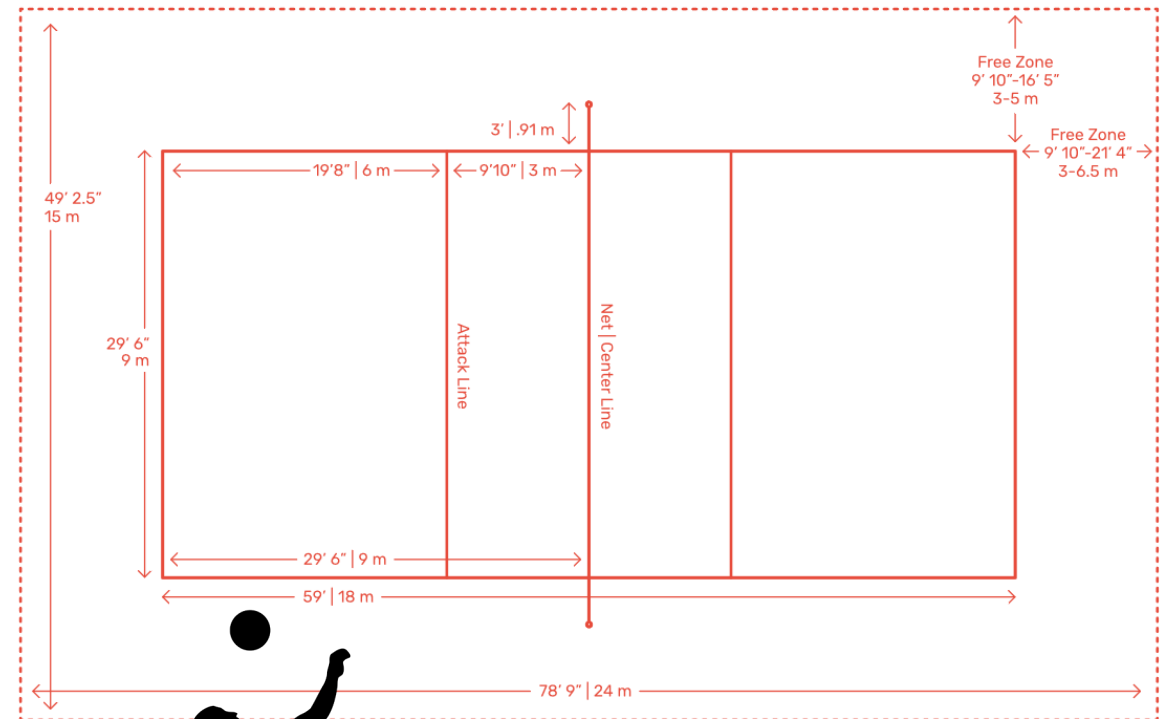

## 04 Handball

### Playground

The rectangular handball court is 40 meters long and 20 meters wide, and contains two goals one on each side. There is a safety zone of at least one meter on the edges of the court, and no less than two meters behind the goal. The floor is painted so that the width of the line is 8 cm in the goal, and 5 cm in other places (such as the edges and the middle of the field).

### Goal

The goal shall be fixed on the ground in the middle of each of the goal lines, with a width of three meters and a height of two meters, and the thickness of the beams shall be 8 cm. The crossbar and uprights shall also be made of wood or any similar synthetic material. The goal is provided with a net that does not allow the ball to bounce directly when shooting.

### Floor

Several types of handball court flooring are available, including:

1. **Wooden floors:** These floors are among the most common types for making handball courts, as they provide high stability, sufficient resilience and traction for the game.
2. **Synthetic Floors:** These floors consist of synthetic materials such as vinyl or polyurethane, and are characterized by their durability and resistance

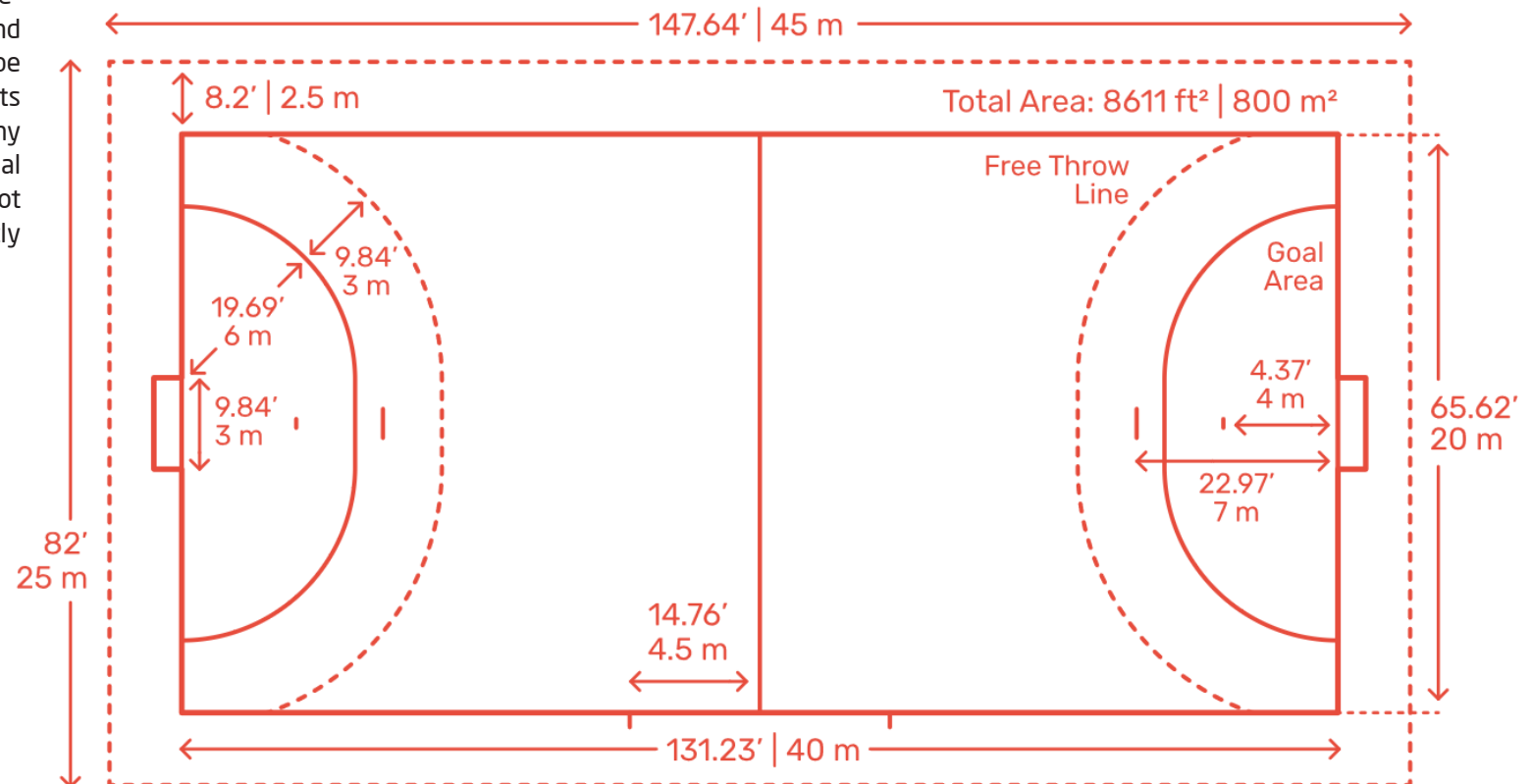



## 05 Five -a-side Football - Futsal

### Playground dimensions

Length: 30 meters as a minimum - 42 (45) meters as a maximum

Width: 20 meters minimum - 30 meters maximum

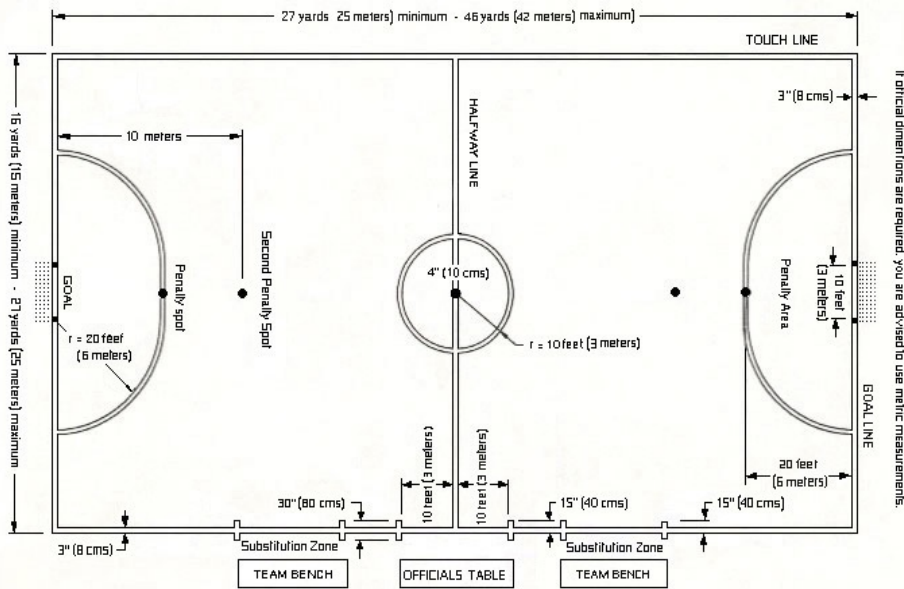

### Futsal court floor

Five -a-side football is played on a smooth, flat rectangular ground without bumps. It is recommended to use wood or synthetic materials for playground floors, and to avoid using cement or asphalt.

## 06 Seven-a-side football - Futsal

### Playground dimensions

Length: 45 meters as a minimum - 50 meters as a maximum

Width: 30 meters minimum - 35 meters maximum

### Futsal court floor

Seven-a-side football is played on a smooth, flat rectangular ground without bumps. It is recommended to use wood or synthetic materials for playground floors, and to avoid using cement or asphalt.

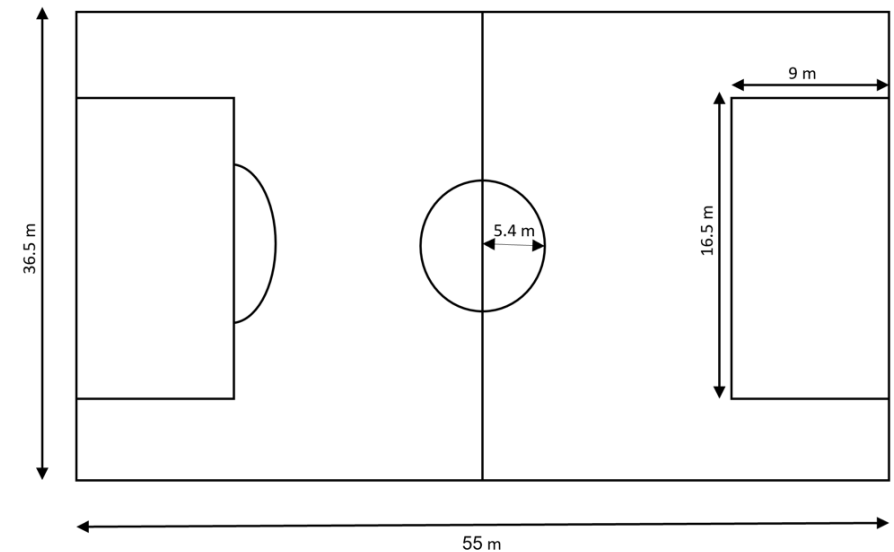

## 07 Bicycle track

### Velodrome

The internationally approved track is 250 meters long, 7 to 9 meters wide, and has a slope of 45 degrees at the turns. Where the path is marked with a set of lines - red, black and blue.

If the track is for beginners, its length is 166 meters, and it must contain a runway that can accommodate 50 to 150 spectators, and if it is for training purposes, its length is 200 meters in addition to a runway that can accommodate 150 to 500 spectators, and if it is for competition purposes, its length is 250 meters and can accommodate 1500 to 3000 spectators, but if according to the international standards, it was 250 meters long and accommodated 3,000 to 5,000 spectators. The materials used in the track are synthetic, wood and concrete materials.

### Floor

- The track floor consists of wood or smooth concrete and the track surface must be completely flat.
- The flatness should be 5mm over 2m.

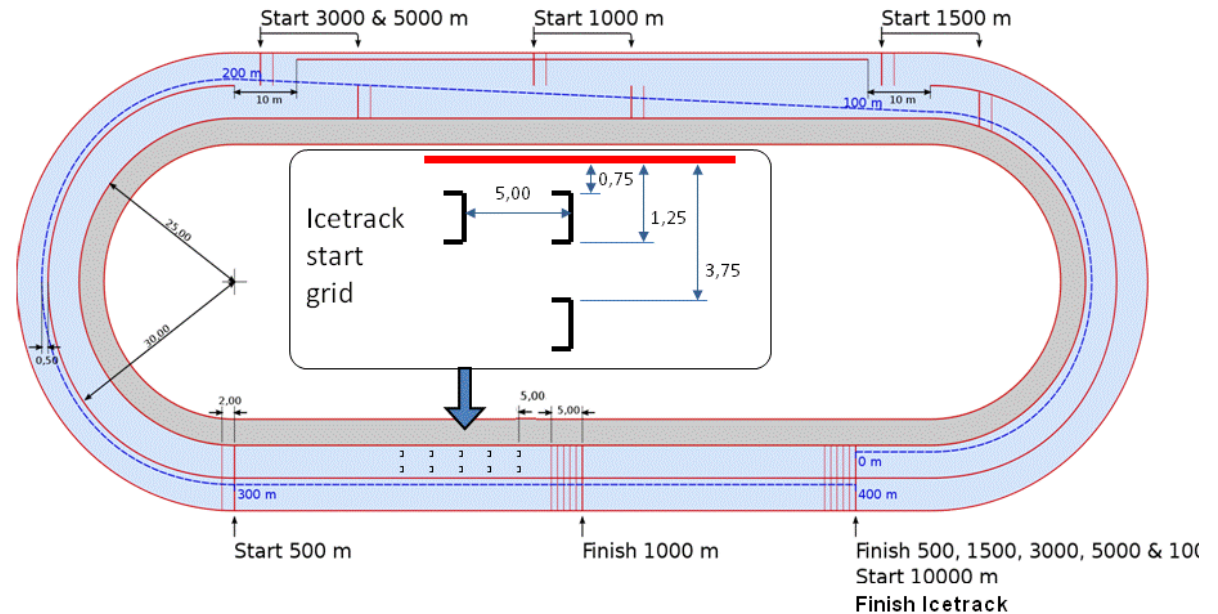
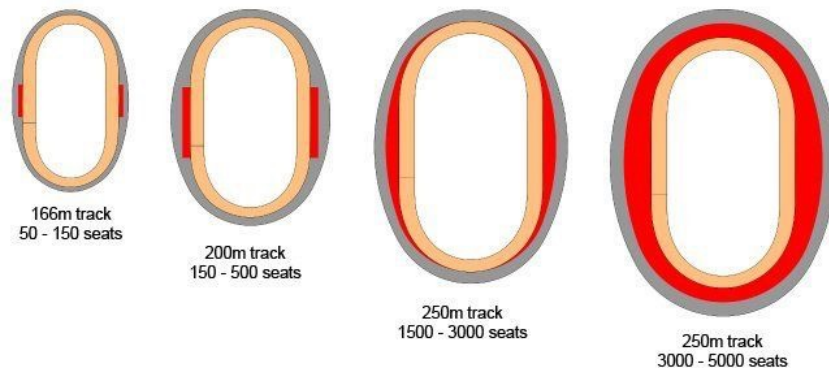

### \* Bicycle track

- The use of internationally approved materials for the floor of the bicycle path, such as: The finest types of rubber to prevent damage
- Observe the separation between the bicycle path and the pedestrian path, and not interfere with vehicles and roads
- Provide safe crossing areas in the areas that conflict with road entrances and exits, and setting up guiding boards and ground signs showing the priority of lanes in the convergence areas.
- The width of the bicycle path ranges from 3 to 6 meters, flat and not tortuous
- For the purpose of continuous rapid training of at least 8 km

# 08 Ice Hockey

## Game specifications

- An ice field divided into three areas: Defense zones, neutral zone and attack zone.
- A ball whose cover is made of white leather, its weight does not exceed 170 g, and its circumference does not exceed 26 cm.
- A stick, which is a wooden bat with a length of 135 cm at most, with a flat bottom, a length of 37 cm, and a height of 9 cm. It is used to hit a flat and round piece.

## Goal

There is a goal on the court that is 1.8 meters wide and 1.2 meters high, at a specified distance from the final borders of the field, and this distance is 3 meters.

## Floor

Flat ice area

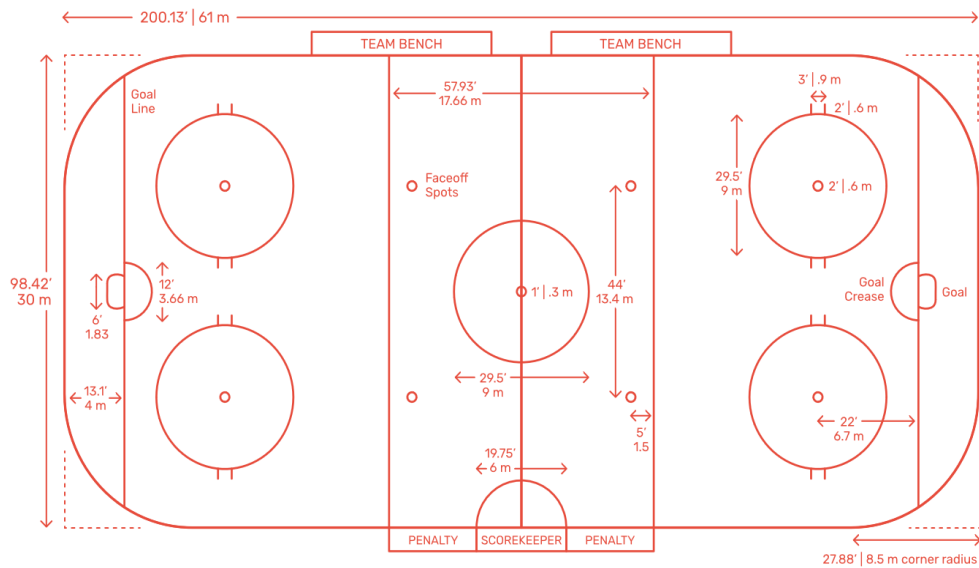

# 09 Table Tennis

## Playground

There must be an area of 5.8 meters in length by 3.4 meters in width, in the middle of which is placed a tennis table measuring 2.7 x 1.5 meters, and it is rectangular in shape and green in color, made of masonite or similar to solid wood, and in the center of the table there is a dividing line that divides it into two parts, each of which represents an area of one player. The court helps to mitigate

## Net

The net is stretched along the table so that it is the same height and the height of the net is 15.25 cm. The length of the ping paddle is usually about 15 cm.

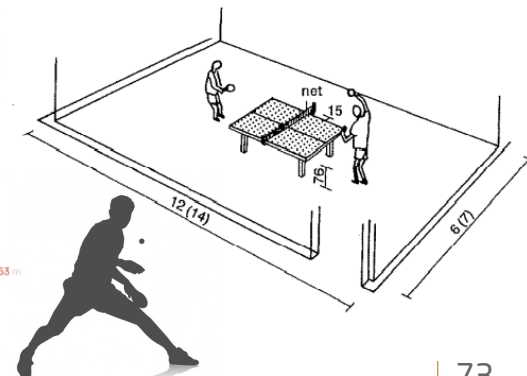
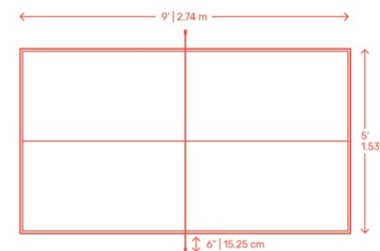
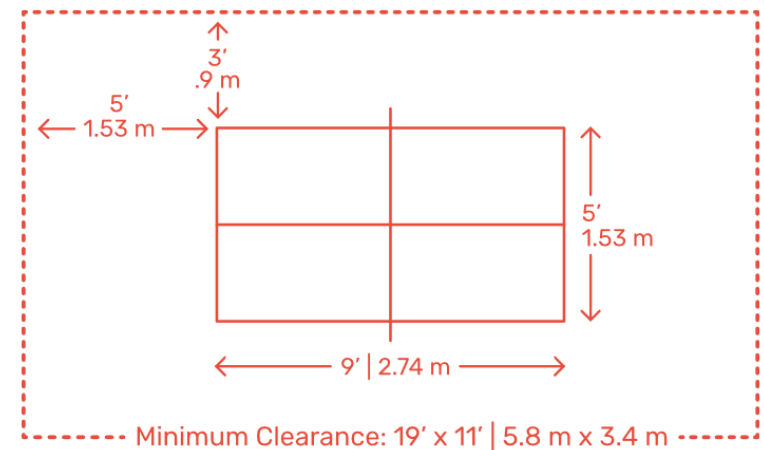



# 10 Squash

## Playground

The squash court consists of a flat floor made of wood / parquet to ensure the stability of the game and the bounce of the ball, and it can be covered or not covered. The surface of the playground contains a front line to separate the front of the playground from behind, and another line in the middle of the playground to separate the left and right sides of the playground. Going down along the side walls to the back wall, its area is 9.75 meters long x 6.40 meters wide, and its maximum height is 5.64 meters.

## Floor

1- Floors of playgrounds made of fiberglass: Most commonly used in making squash courts, these floors consist of a layer of fiberglass with a layer of suitable adhesive. These floors are characterized by durability, good traction and compliance with the standards of the International Squash Federation.

2- Polyurethane playground floors: These floors are characterized by durability, good traction and light weight, providing good stability for players.

3- Vinyl floors: These floors are common types, and they are characterized by durability, flexibility and good friction. It also offers the advantage of easy cleaning.

4- The floors of the playgrounds made of wood: Different types of wood are used to make these floors, and they are durable, aesthetic, and flexible. However, these floors require regular maintenance and careful cleaning.

5- Playground floors made of rubber: These floors are characterized by flexibility and good friction, and are sometimes used in open-air squash courts, as they provide good resistance to various weather factors.

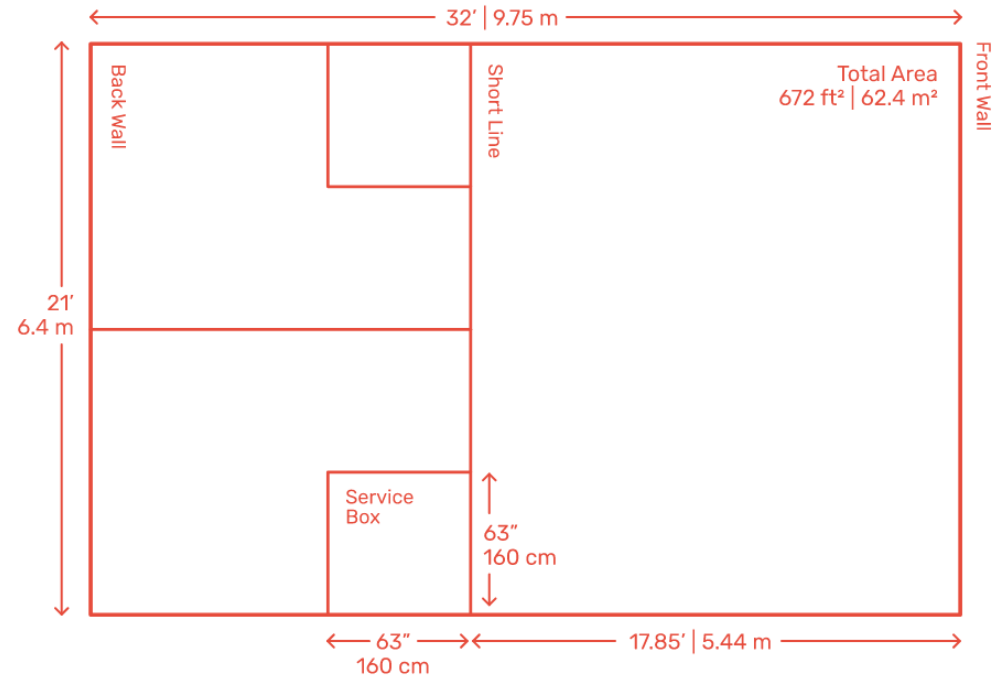

# 11 Gymnastics

## Gymnastics

Gymnastics is a type of sport that is individual in its performance, and it is the process of performing a series of movements on the apparatus used in gymnastics, which are different, such as the devices on which the person moves. Those devices used in sports have different types, including the technical competition devices for men, which consist of 6 devices, namely: Floor mat, pommel horse, jump table, parallel bars, horizontal bar, and pommel. For women, there are two types: Artistic gymnastics and rhythmic gymnastics.

**POMMEL HORSE**

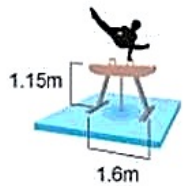

**RINGS**

Balance & arm strength



**PARALLEL BARS**

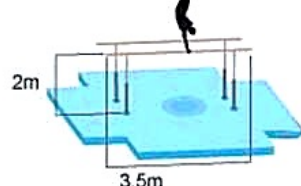

**FLOOR**

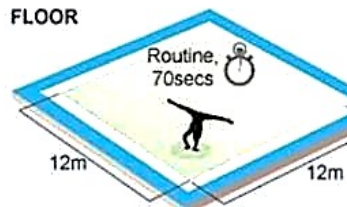

**VAULT**

25m run up

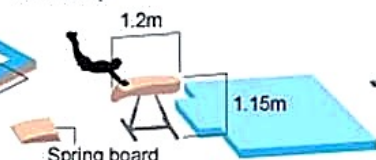

**HIGH BAR**

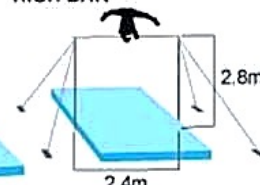

**Artistic & Acrobatic Gymnastics  
Men's and Women's**

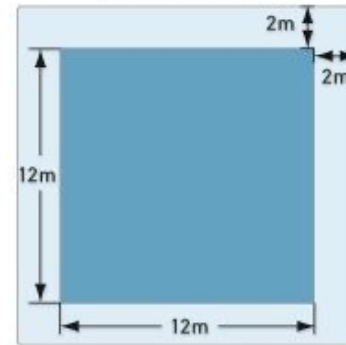

**Aerobic Gymnastics**

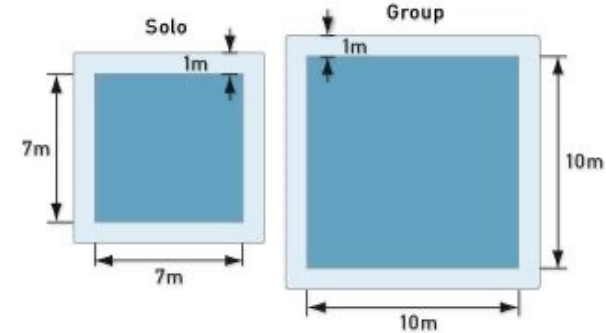

**Rhythmic Gymnastics**

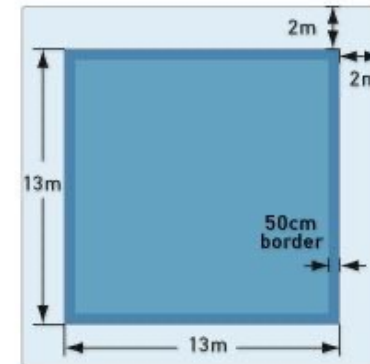

**Recommended Ceiling Height (RG only)**

10-12m

**Minimum Ceiling Height (RG only)**

8m



## Floor

It is a ground rug covered with carpets, with felt pieces underneath and at the bottom wooden pieces placed on plastic pieces to help jump and absorb landings.

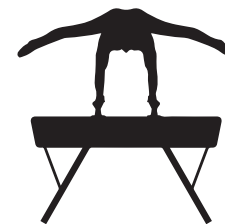

## 12 Judo

### Playing area

The maximum size of the playing area is 16 x 16 meters and the minimum of it is 14 x 14 meters. The playing area is divided into two areas: The main play area has a maximum area of 10 x 10 m and a minimum of 8 x 8 m, and the danger zone that surrounds the main play area is a meter wide.

### Playing area (rug)

There is a vinyl or cotton rug, the bottom surface of the rug may be bare or anti-slip. A bare surface is recommended if the mat is surrounded by a wooden frame, or an anti-slip underlayment surface so that it adheres to the ground and prevents moving and spreading as the athletes fall.

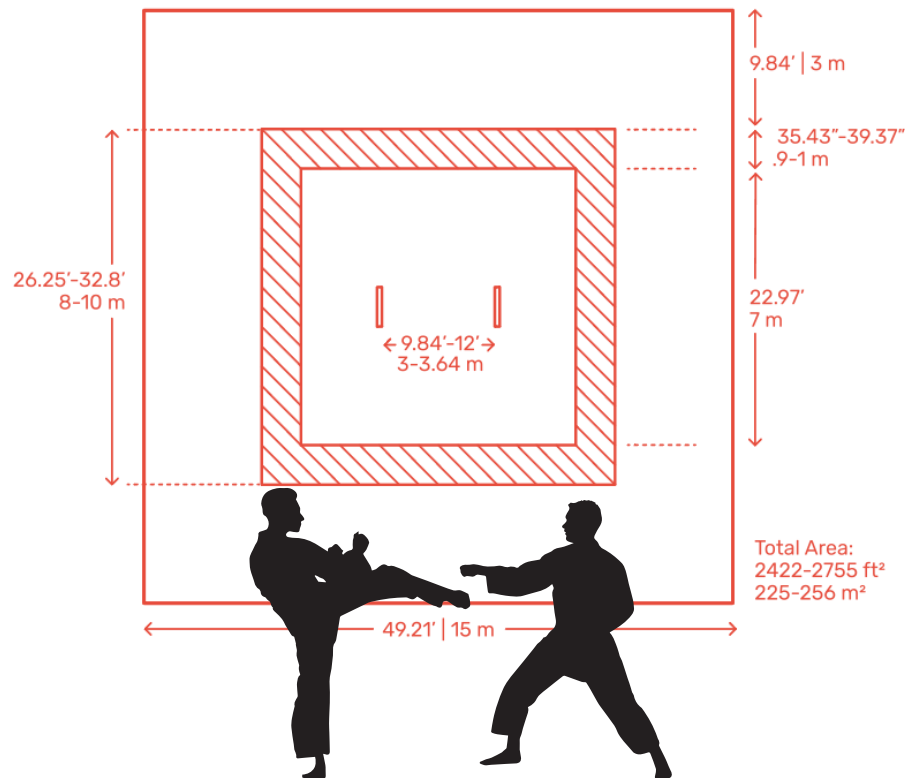

## 13 Jiu-jitsu

### Competition areas

The area of the competition arena ranges from a minimum of 64 square meters to a maximum of 100 square meters. That area is divided into two parts: The first is internal and consists of at least 18 pieces of tatames of blue color, while the second is external and consists of 14 pieces of red color.

### Allocated space

As the case in Judo, the maximum size of the playing area is 16 x 16 meters and the minimum of it is 14 x 14 meters. The playing area is divided into two areas: The main playing area has a maximum area of 12\*12 meters. The danger zone surrounding the main playing area is a meter wide.

### Floor

- The Jiu-jitsu floor is made of an EVA filler which is composed of ethylene-vinyl acetate, resulting in a soft yet durable polymer that is ideal for high impact workouts and sports with a good amount of cushioning.
- This material withstands pressure and beatings and can receive shocks and return to its original nature.

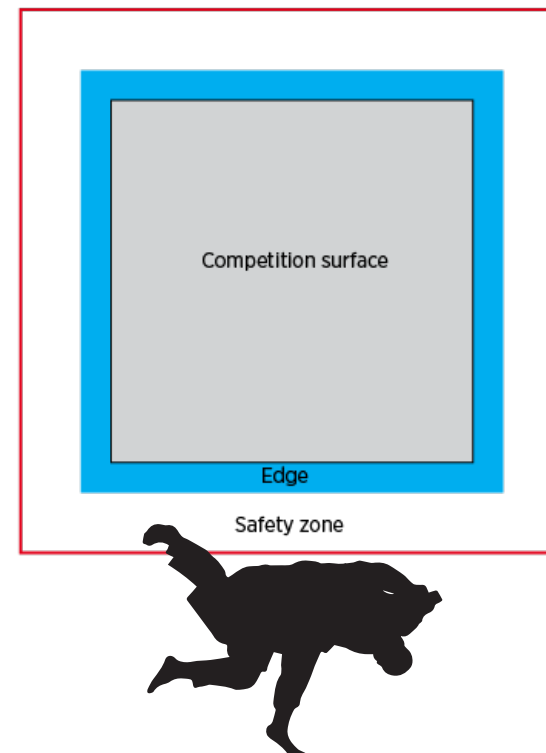



# 14 Weightlifting

## Competition areas

The area of the competition arena is between 4m in length and 4m in width. The referees are located to the right and left and in front of the competitors.

## Floor

The transition material for floors is often rubber because it is high in thickness, shock absorbent, easy to clean, noise reducing, and antibacterial.

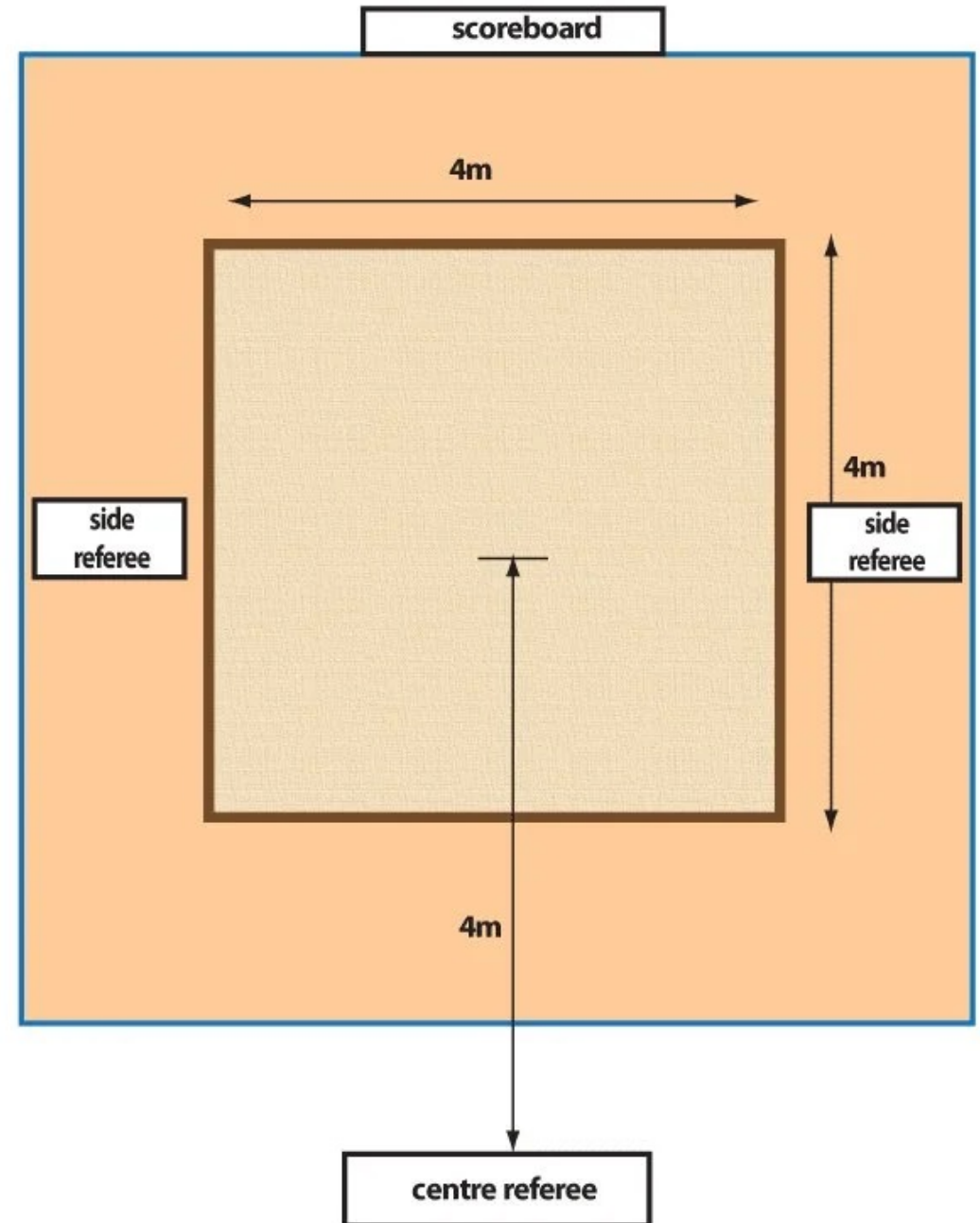
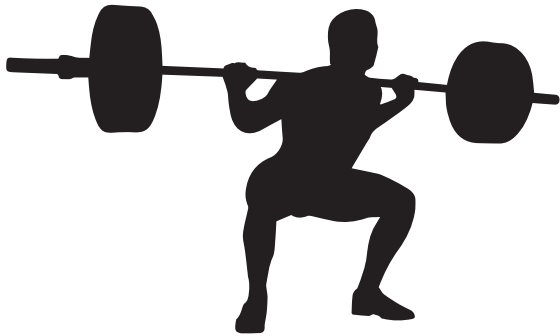

# 15 Fencing

## Competition areas

The area of the outer fencing ring is 26m in length and 8.5m in width, while the inner area consists of 14m in length and 1.5-2 in width.

There are three important areas in the interior region, which are as follows:

- The warning area consists of 2 m
- The guard line area consists of 4 m
- Surface runoff area consisting of 1.5 - 2

## Floor

The types of fencing floors vary according to the specifications of the different leagues and tournaments, and there are many types available that can be used for training and competition purposes. The following are common types of fencing floors:

1- Vinyl Floors: These floors are flexible, have good friction, and are slip-resistant. They are also easy to clean and maintain, and are used in many training and tournament venues.

2- Wooden floors: These floors are durable and aesthetic. They also provide an outstanding fencing experience. These floors are used in tournaments and training venues that are keen to provide an elegant and luxurious environment for fencing.

3- Rubber Floors: These floors are a popular type of fencing floor, and they are resilient, durable, and have good traction properties. They are used in many tournaments and training venues that focus on the comfort and safety of fencers.

4- Fiberglass Floors: These floors are durable, have good traction, slip-resistant, and easy to clean and maintain. They are used in many training venues and tournaments.

5- Tile floors: These floors are traditional types of fencing floors, and are characterized by durability and aesthetics. They are used in many training and tournament venues that are keen to provide a traditional and luxurious environment

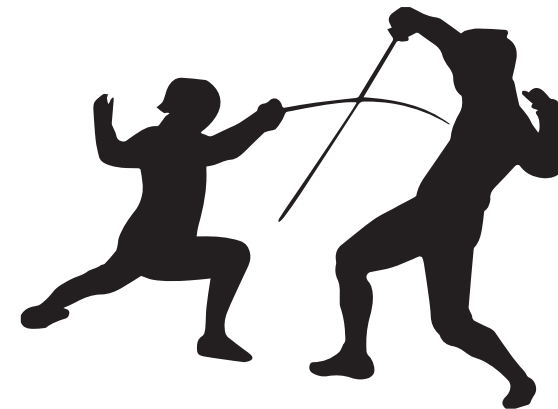
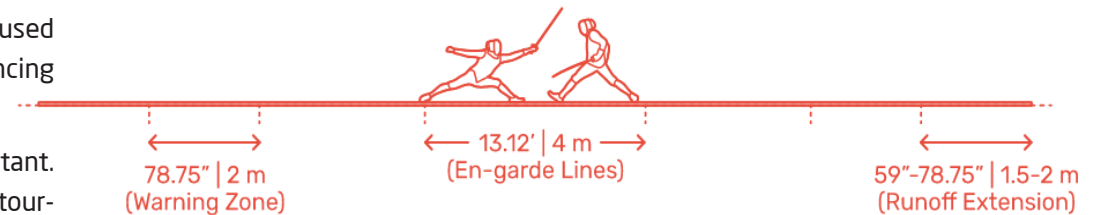
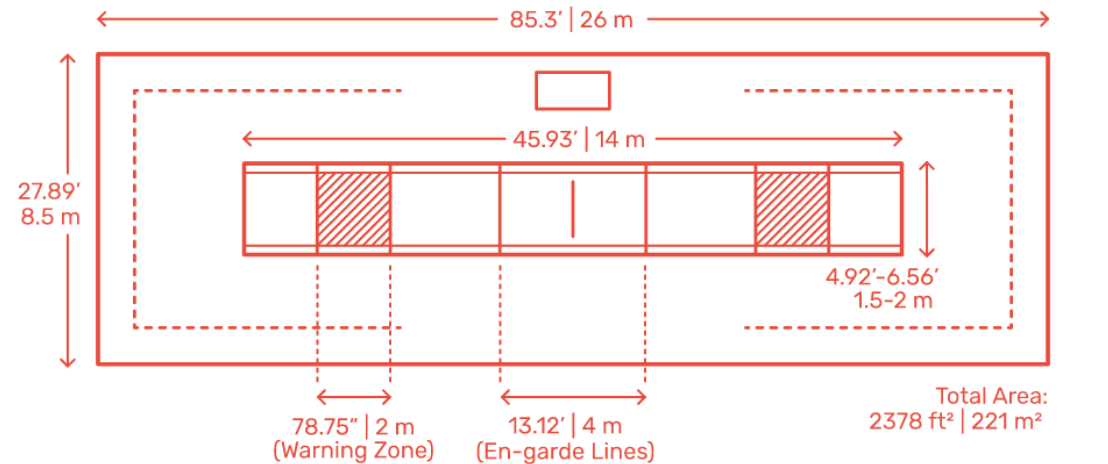

# 16 Boxing

## Competition area

The competition arena measures 6.01m x 6.01m inside the ropes, and the arena is 100 cm above the ground. It is equipped with four pillars to prevent boxers from being injured.

## Floor

The floor of the arena must be made of rubber or other approved materials that are of good quality and flexibility. They must be non-slip and cover the entire platform, with a size of not less than 1.5 cm and a thickness not exceeding 2.0 cm.

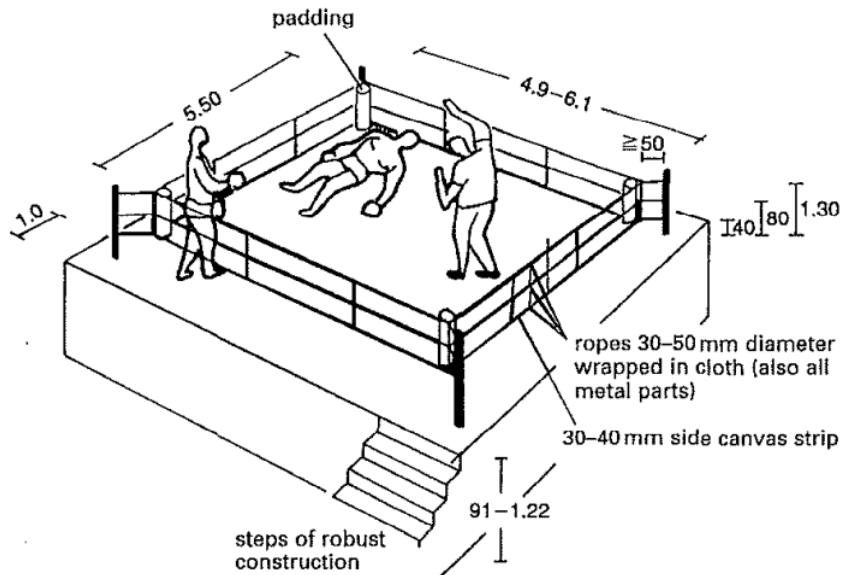
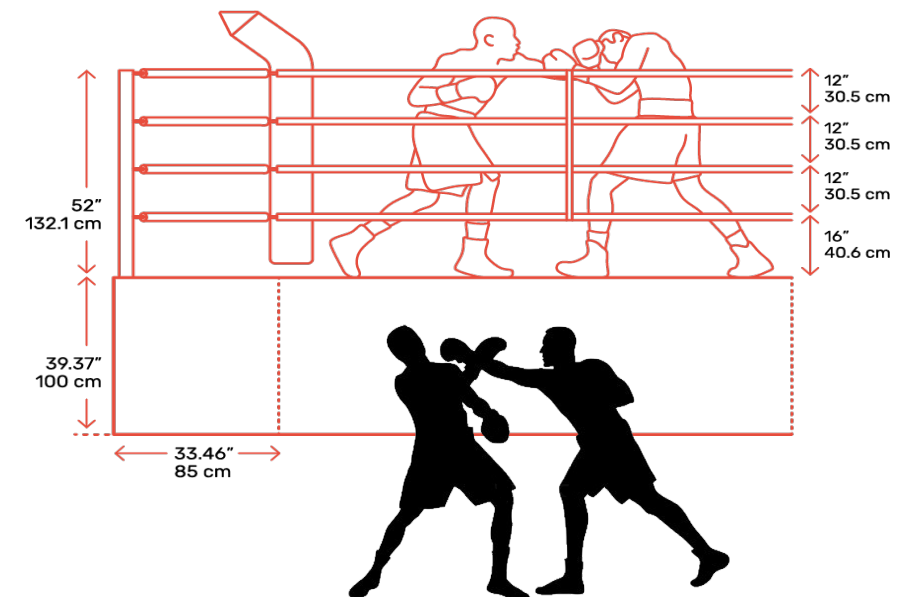
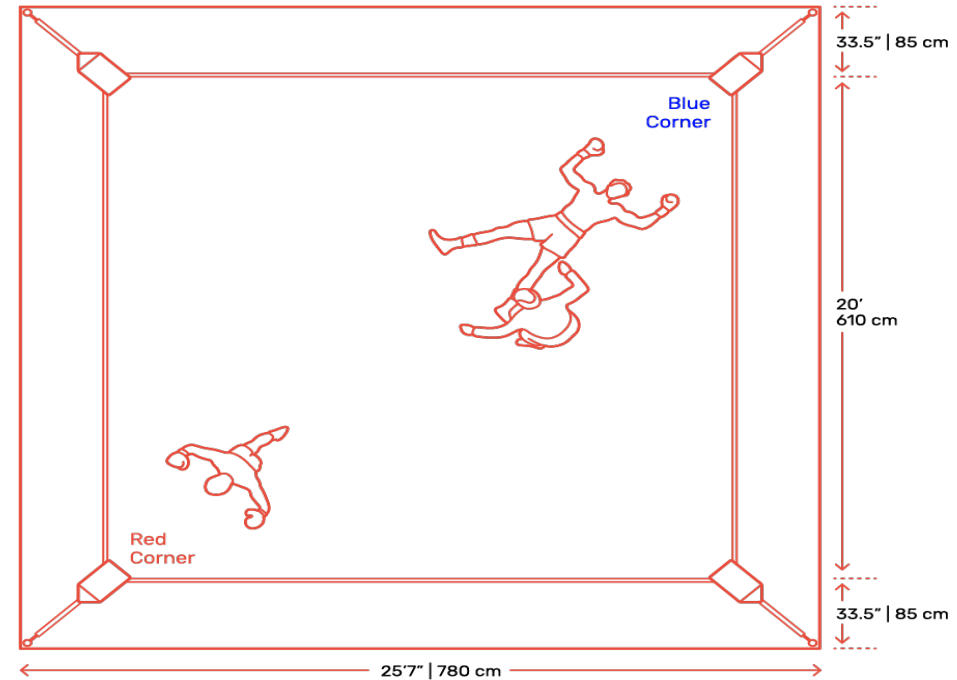



# 17 Bowling alley

## Play field and ball specification

The bowling alley consists of a very long, smooth wooden lane. It is 18.29 meters long and 1.05 meters wide. It is bordered on each side by a 23 cm wide lane, so that the width of the track, including the two lanes, is about 152 cm.

The ball has a circumference of 70 cm and weighs no more than 7.3 kg. It is held in the hand in order to aim it at objects in the form of bottles made of wood or plastic. Each one is 38 cm long and weighs between 1.3-1.6 kg.

The number of lanes allowed for international matches is between 24 and 36 lanes, according to American standards and specifications.

## Floor

Very smooth long wood floor

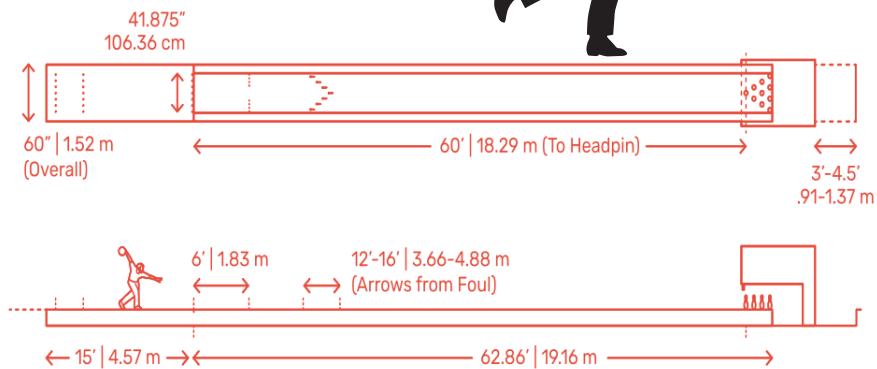

# 18 Billiards and snooker table

## Billiards and snooker table

The snooker and billiard table consists of a wooden frame with a surface covered with a soft cloth of 85% wool and no more than 15% nylon. The table also contains six pockets for hitting the target.

The height of the table above ground level is between 85 cm and 87.5 cm

The design of the table should not contain sharp edges or materials that could cause injury or damage to clothes.

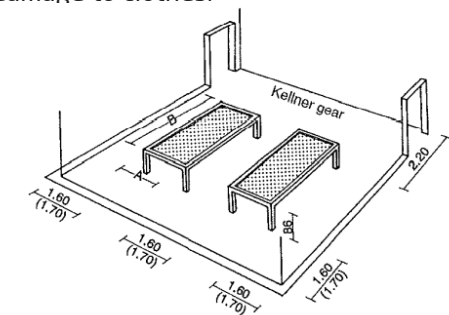
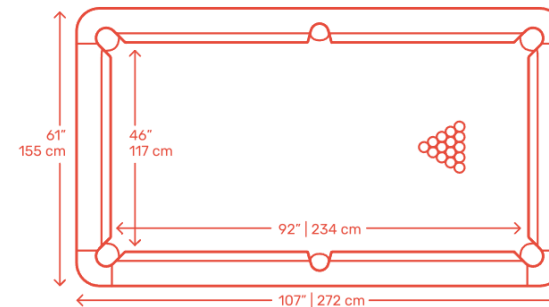
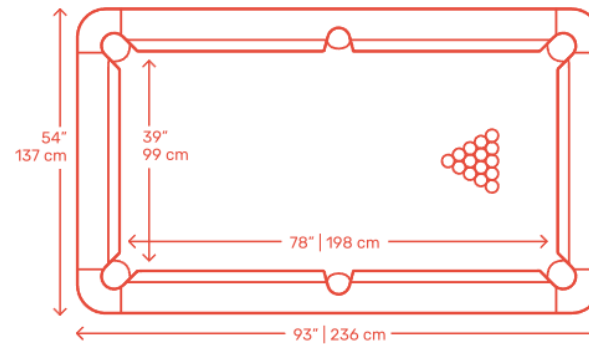
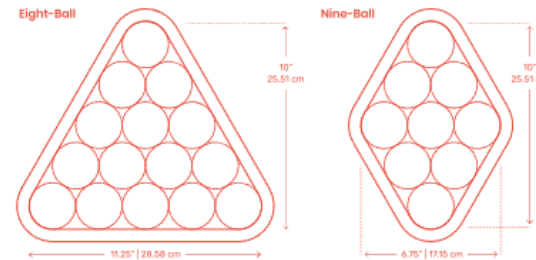

- ◆ The recommended minimum space around the table is 2.5 meters
- ◆ Lighting: It should be at least 520 Lux and be placed around the table so that it is not directed at the players

# 19 Shooting

## Shooting ranges

### Fields for gun activities

6 compact models of Trap and Skeet shotguns, four of which are equipped for Compak Sporting.

All designs are equipped with Laporte throwing machines, Elettronica Progetti electronic scoreboards and Phonopull systems.

### Fields for shooting activities

- Indoor and outdoor shooting range
- Air rifle and pistol field
- Indoor shooting range - 10 meters with 80 firing points
- Outdoor shooting range - 25 meters with 12 groups of 5 targets
- Indoor shooting range - 25 meters with 12 groups of 5 targets
- Outdoor shooting range - 50 meters with 80 shooting points
- Indoor shooting range - 50 meters with 10 firing points
- Outdoor shooting range - 300 meters with 40 shooting points
- Operation of the indoor shooting range using 3 devices targeting the finals hall: 10 meters with 12 firing points, 25 meters with 3 groups of 5 targets, 50 meters with 10 firing points
- All air rifle and pistol shooting ranges are equipped with Sius Ascor targets.

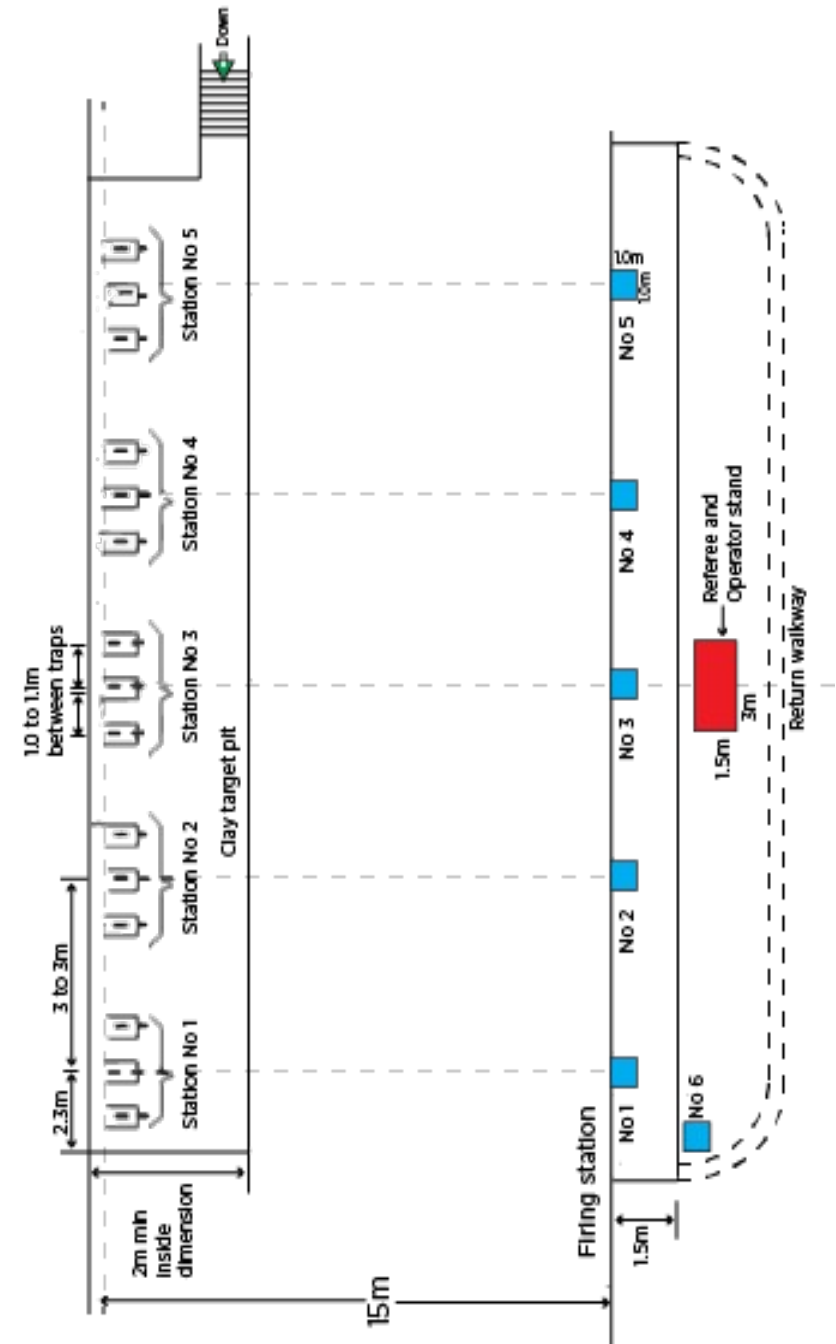
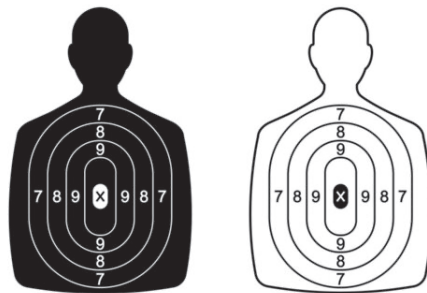

## 20 Badminton

### Badminton court

Badminton is completely different in terms of playground specifications and laws from other sports, and therefore we will get to know the most prominent specifications of the playground for this sport for professionals and international competitions as follows:

- The playground is 13.4 meters long
- The playground is 6.1 meters wide
- The playground is divided by a net in the middle, which makes each section equal to the other.

### Floor

#### Synthetic floors:

Synthetic Badminton court floorings have artificial materials as its source. They are designed keeping in mind the specific needs of the games modern format and are extremely player-friendly.

There are predominantly two types of synthetic badminton court flooring:

- PVC/PU Floors:
  - Anti-slip quality.
  - The bounce rate of the floors is good
  - The softer surface creates higher rolling resistance for badminton players using sports chairs.
- Acrylic floors:
  - Acrylic courts are usually made of hard materials such as concrete or asphalt and covered with an acrylic adhesive. We use this material to cover the surface and denote the playing lines.
  - It is available in different styles and reasonable prices and is somewhat similar to PVC/PU floors.

#### Wooden floor:

- Solid wood is the most common form of floors for wooden badminton courts.
- It requires regular care and polishing with a coating to give it a high quality sheen and longevity
- Good at absorbing pressure
- Waterproof surface. Solid wood is the most common form of floors for wooden badminton courts.
- It requires regular care and polishing with a coating to give it a high quality sheen and longevity
- Good at absorbing pressure
- Waterproof surface.

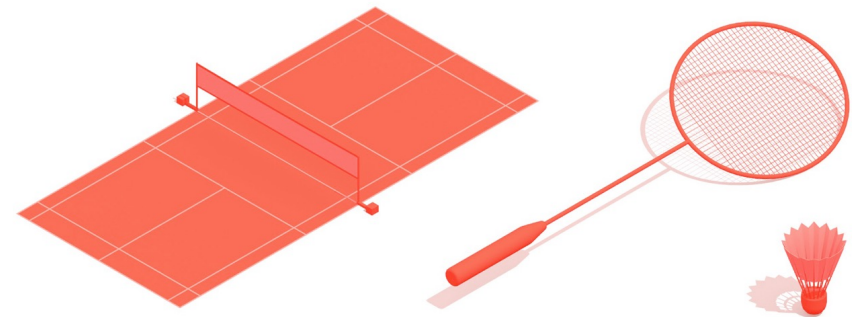
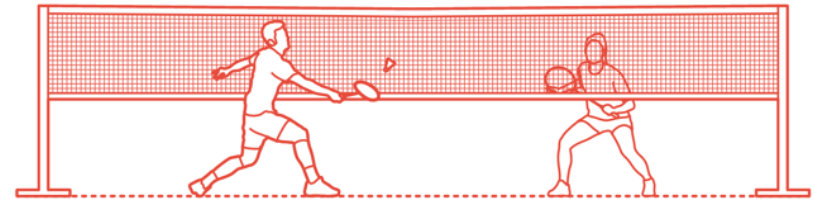
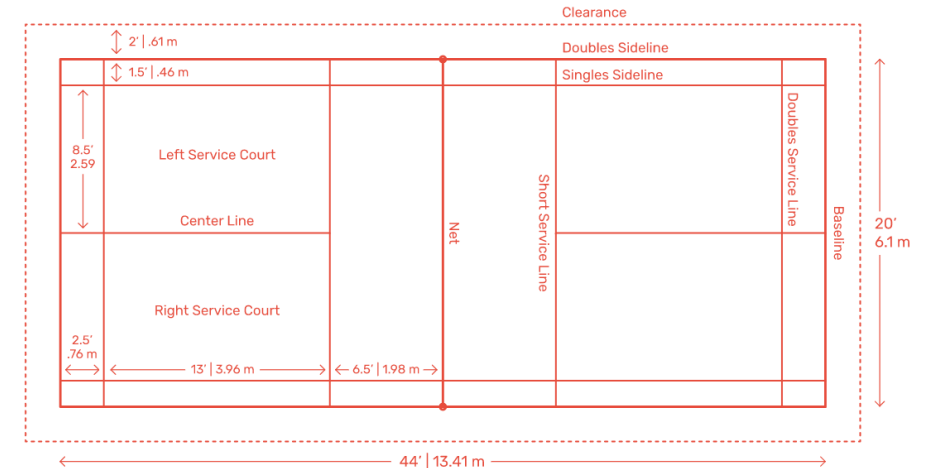





# Water Sports |



# 01 Swimming

## Pool specifications

The Olympic swimming pool is 50 meters long, 25 meters wide and 2 meters deep minimum and 3 meters recommended, divided into 10 lines each with a width of 2.5 meters.

The semi-Olympic pool is 25 meters long, 25 meters wide and 2 meters deep minimum and 3 meters recommended, divided into 10 lines, each 2.5 meters wide.

The end wall of the pool must be perpendicular to the surface of the water and made of solid materials with a non-slip surface so that the competitor can touch it and push when turning without danger. The lighting intensity of the entire pool should not be less than 1500 lux

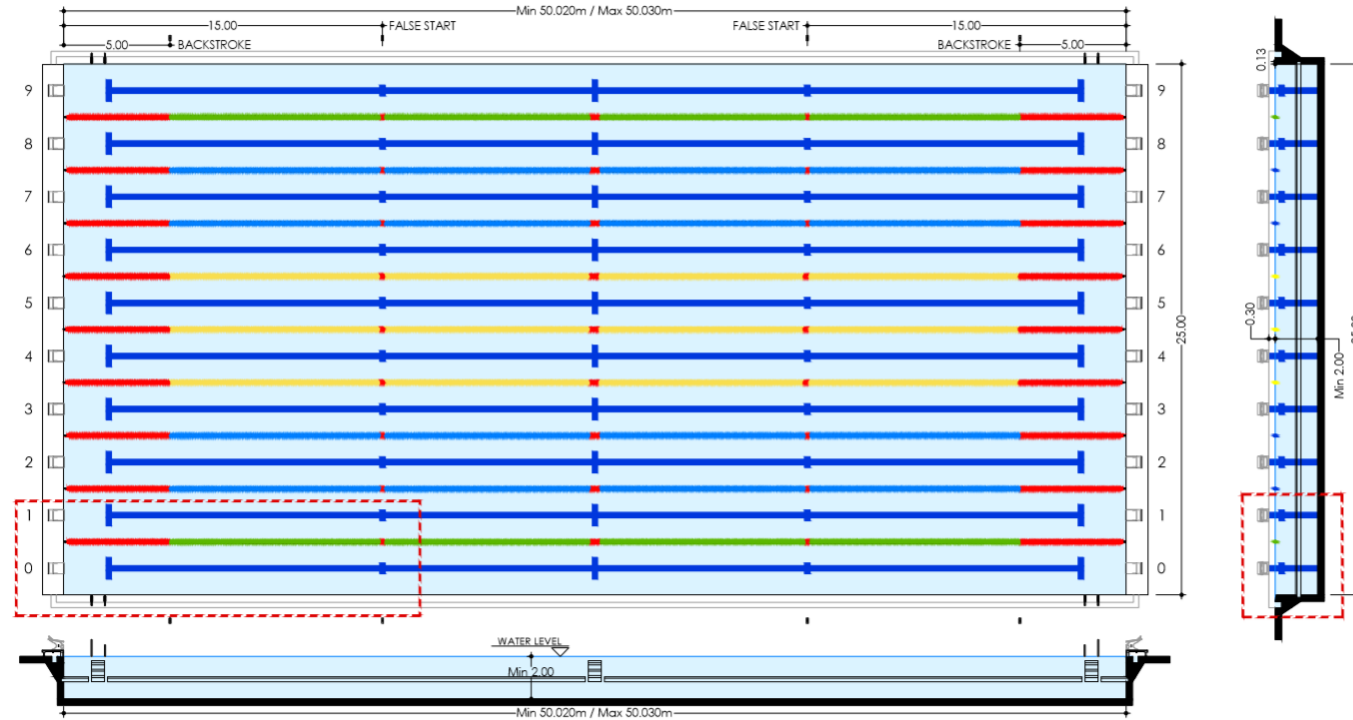

**FR 3.8 LANE ROPES**

9	Green
8	Blue
7	Blue
6	Blue
5	Yellow
4	Yellow
3	Yellow
2	Blue
1	Blue
0	Green

FIG. 4

**FR 2.14 FINA LANE MARKINGS**

WIDTH OF LANE MARKINGS, END, LINES, TARGETS	A	0.25m ± 0.05m
LENGTH OF END WALL TARGETS	B	0.50m
DEPTH TO CENTRE OF END WALL TARGETS	C	0.30m
LENGTH OF LANE MARKER CROSS LINE	D	1.00m
WIDTH OF RACING LANES	E	2.50m
DISTANCE FROM END OF LANE LINE TO END WALL	F	2.00m
TOUCH PAD	G	2.40m x 0.90m x 0.01m
DIST. FROM CENTRE OF CROSS LINE TO END WALL	H	15.00m

FIG. 5

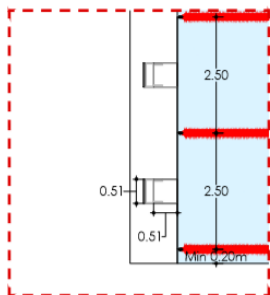

FIG. 3 STARTING PLATFORMS

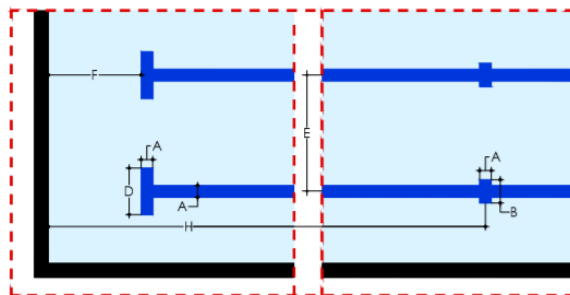

FIG. 6 PLAN LANE MARKINGS

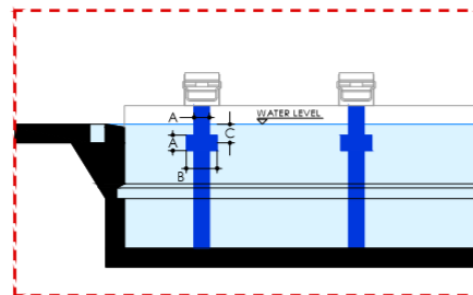

FIG. 7 END WALL LANE MARKINGS

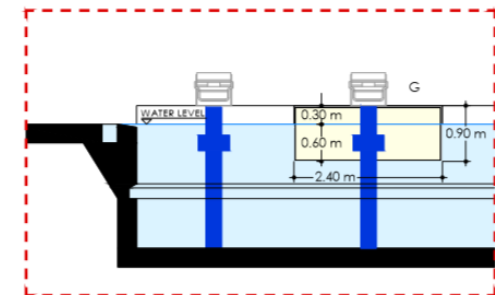
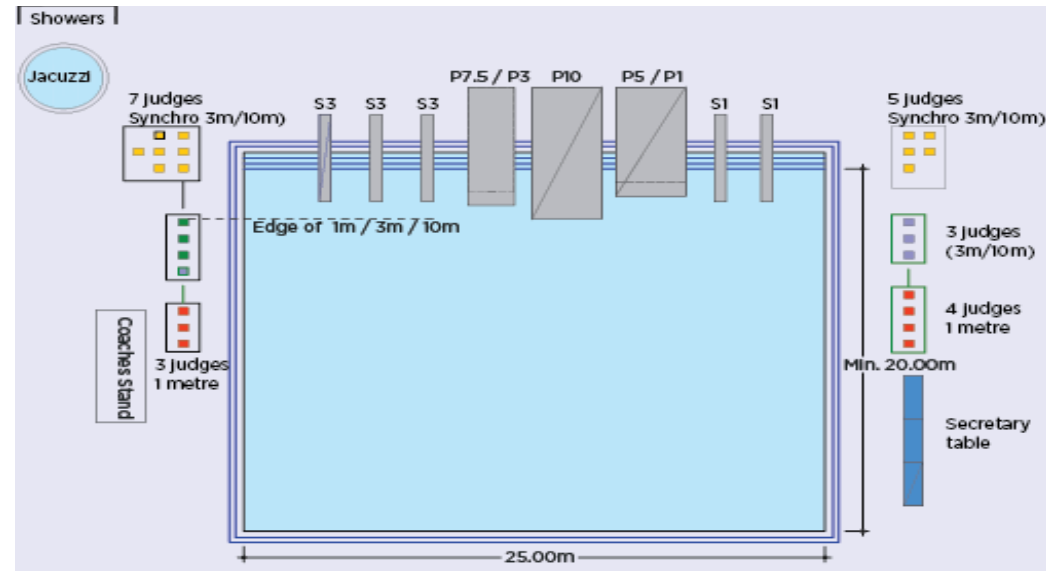

FIG. 8 TOUCH PANEL (2.40m x 0.90m x 0.01m)

## 02 Diving

### Specifications of the pool and platforms:

- The preferred thickness for the leading edge of the platform is 0.2m but not exceeding 0.3m, and may be vertical or inclined at an angle of no more than 10° to the vertical within the landing line.
- When a platform is directly below another platform, the platform above projects at least 0.75m (preferably 1.25m) outside the platform below.
- The back and sides of each platform (except for 1.0m or less platforms) are surrounded by guardrails up to 1m from the platform edge with a minimum empty space of 1.8m between vertical pairs. The minimum height is 1.0m and has at least two horizontal crossbars placed outside the platform, starting from 1.0m from the front edge of the platform.
- Each platform may be accessed by suitable ladders as required by the countries building regulations or applicable health and safety standards.
- Platforms of 1m and 3m are used for training and 5m, 7.5m and 10m for tournaments.



### Water depth according to the FINA Diving Guide

- The preferred water depth for a 1m platform is 3.3m
- The preferred water depth for a 3m platform is 3.5m
- The preferred water depth for the 5m platform is 3.8m
- The preferred water depth for a 7.5m platform is 4.5m
- The preferred water depth for a 10m platform is 5m

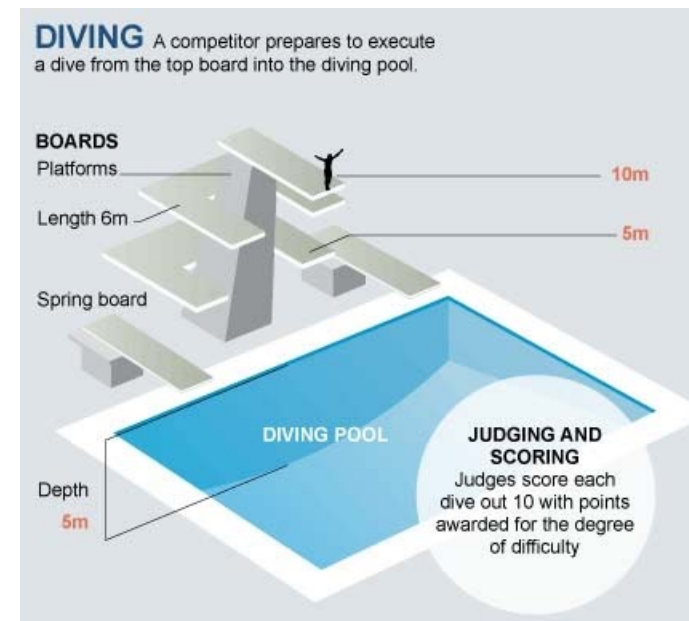



## 6

## Common mistakes in designing and implementing sports facilities

Closed facilities	Open/outdoor playgrounds
<ul style="list-style-type: none"> <li>• Unavailability of warehouses adequate spaces and ventilation, or their poor locations</li> <li>• Not choosing the appropriate floors for the types of sports practiced</li> <li>• The use of floors with a soft / smooth surface in the changing and showering areas, which poses a risk of slipping</li> <li>• Lack of convenient and safe ways to fix vertical lighting (from the ceiling)</li> <li>• Unavailability of a suitable place (room) to receive or deliver devices and tools</li> <li>• Unavailability of separate rooms for maintenance</li> <li>• Poor chemical maintenance of swimming pools</li> <li>• Unsuitable natural lighting for sports (windows / glass windows facing east or west)</li> <li>• The absence of a suitable elevator for transporting heavy equipment if the facility consists of multiple floors</li> <li>• The lack of adequate facilities for people of determination</li> <li>• The absence of electrical outlets with a suitable distribution for television photography or other purposes</li> <li>• Wasting the space for changing rooms by placing spaced rows of boxes</li> <li>• Not studying the traffic around the facility before construction.</li> <li>• Not studying human movement inside the facility</li> <li>• Multiple use of some playgrounds without appropriate barriers/separators between them</li> <li>• Lack of private rooms for meetings and lectures</li> <li>• There are no designated places inside the walls for water coolers and fire extinguishers</li> </ul>	<ul style="list-style-type: none"> <li>• Distributing the playgrounds randomly</li> <li>• Using unsuitable floors for all seasons of the year</li> <li>• Lack of external lighting or the weakness and poor distribution of it in the playgrounds</li> <li>• The closeness of the courts to each other in a way that affects practice</li> <li>• Weakness in the bases of the nets surrounding some playgrounds, so that they do not withstand wind resistance/ directions</li> <li>• Lack of tendencies for water drainage or poor planning for it</li> <li>• The far distance between the playgrounds and the service facilities (toilets, changing rooms... etc.)</li> <li>• There are no safety barriers in the fields of sports or practice</li> <li>• Failure to take into account security and safety factors in playgrounds in general</li> <li>• The lack of facilities in the entrances, corridors and stands... etc., for people of determination</li> </ul>

## Sources and references

1. According to the standards and requirements of the local and international federations for each sporting activity
2. United Arab Emirates Football Association [www.uaefa.ae](http://www.uaefa.ae)
3. United Arab Emirates Basketball Association [www.uae.basketball](http://www.uae.basketball)
4. United Arab Emirates Volleyball Federation [www.uaevba.ae](http://www.uaevba.ae)
5. United Arab Emirates Handball Federation [www.uaehandball.net](http://www.uaehandball.net)
6. UAE Tennis Federation [www.uaetennis.ae](http://www.uaetennis.ae)
7. United Arab Emirates Padel Tennis Association [www.uaepa.ae](http://www.uaepa.ae)
8. UAE Wrestling and Judo Federation [www.uaewjf.com](http://www.uaewjf.com)
9. Emirates Jiu-Jitsu Federation [www.uaejjf.com](http://www.uaejjf.com)
10. UAE Swimming Federation [www.uaeswimming.net](http://www.uaeswimming.net)
11. UAE Bowling Federation [www.emiratesbowling.com](http://www.emiratesbowling.com)
12. Emirates Billiards and Snooker Federation [www.uaebsa.ae](http://www.uaebsa.ae)
13. General Authority for Sports <https://gas.gov.ae/>
14. Attached photo guide [www.dimensions.com](http://www.dimensions.com)
15. Shooting range photos <https://www.dlgsc.wa.gov.au/sport-and-recreation/sports-dimensions-guide/shooting>
16. Photos of the rhythmic swimming and diving pool <https://www.rulesofsport.com/sport/diving>
17. Velodrome Photos <https://www.icebyk.com/ITC.htm>
18. Padel sports playgrounds photos <https://padten.wordpress.com/court-dimensions/>
19. Weightlifting <https://olympics.com/tokyo-2020/en/sports/weightlifting/>
20. Fencing <https://www.rulesofsport.com/sports/fencing.html>
21. Shooting Ranges - Al Ramii Sport Club ([alramiiclub.qa](http://alramiiclub.qa))
22. The World Sports Book - Fourth Edition
23. Abu Dhabi International Building Code - 2013
24. Community Facilities Planning Guide for the Department of Municipalities and Transport - (Version 2.0) 2020
25. FIFA Guide to Football and Stadium Design - Fifth Edition - 2011
26. FINA Diving Guide - February 2020
27. Badminton Courts - <https://www.kreedon.com/badminton-court-flooring-guide>

Abu Dhabi Sports Council  
P.O. Box 127722, Abu Dhabi  
United Arab Emirates

T: +971 2 4088999  
F: +971 2 6818883  
[www.adsc.ae](http://www.adsc.ae)



@Abudhabisc



@abudhabisc



ADSC ADSC



Abu Dhabi SC



ADSC ADSC